

Maintenance sheet 540 68A166-4

A. Troubleshooting

If the error code is indicated on the green LED (Refer to Section C) on the PCB (Part #701) of the water heater (and/or the remote controller), refer to Section B.

<< It takes a long time to get hot water at the fixtures >>

- The time it takes to deliver hot water from the water heater to your fixtures depends on the length of piping between the two. The longer the distance or the bigger the pipes, the longer it will take to get hot water.
- If you would like to receive hot water to your fixtures more quickly, you may want to consider a hot water recirculation system.

<< The water is not hot enough or turns cold and stays cold >>

- Compare the flow and temperature. Refer to the "Output temperature chart" in the Installation manual.
- Check cross plumbing between cold water lines and hot water lines.
- Check if the gas supply valve is open fully, the gas line is sized properly, and the gas supply pressure is within specified limits. Refer to the "Gas supply and gas pipe sizing" in the Installation manual.
- Check the set temperature, and change the set temperature with the remote controller or the DIP switch setting. Refer to Section D.
- Refer to the "Water circuit" in this section.
- Is the Easy-Link or Multi-Unit System set up correctly?

<<The water is too hot>>

- Check the set temperature and lower.

<<The hot water is not available when a fixture is opened>>

- Refer to "Power supply circuit" and "Water circuit" in this section.
- Check if the gas supply valve is open fully, the gas line is sized properly, and the gas supply pressure is within specified limits.
- Is the Easy-Link or Multi-Unit System set up correctly?

<<Fluctuation in hot water temperature>>

- Check if the filter on the cold water inlet is cleaned. (Part #406)
- Check if the gas line is sized properly and the gas supply pressure is within specified limits.
- Check for cross connection between cold water lines and hot water lines.
- Refer to the "Water circuit" in this section.
- Is the Easy-Link or Multi-Unit System set up correctly?

B. Error codes The 341, 751 and 941 error codes are applied to the 540 Indoor only.

031: Incorrect DIP switch setting

- Check the DIP switch settings on the PCB. Refer to Section D.

101: Warning for the "991" error code

- Check the gas type of the house (and/or the building).
- Check if there is any blockage in the intake air and/or exhaust. Refer to the "Venting Instructions" in the Installation manual.
- If the water heater is installed as a direct-vent system, check whether there is enough distance between the intake air terminal and the exhaust terminal. Refer to the "Vent termination clearances" in the Installation manual.
- Check the total vent length. Refer to the "Venting instructions" in the Installation manual.
- Check the altitude/elevation of area of where the water heater is installed. Refer to the "High-altitude function" of Section for the correct DIP switch settings.
- Check if there is grease and/or dirt in the burner (Part #101) and the fan motor (Part #103), especially if the water heater has been installed in a contaminated area.
- Check if there is dust and lint in the heat exchanger.
- Check the manifold pressure of the water heater. Refer to the rating plate of the water heater.

111: Ignition failure*

- Check the gas supply and inlet gas pressure.
- Check if the Hi-limit switch (Part #412) is functioning properly.
- Check for connection/breakage of wires (Part #413, 708, 709, 711), and/or soot on the flame rod (Part #108). And then if the O.H.C.F (Part #413) has a breakage, **Consult the manufacturer.** Check if there is a buzzing spark ignition sound coming from the burner (Part #101) when water heater prepares for combustion.
- Listen for the double "clunk" sound coming from the gas valve assembly (Part #102) when water heater goes into combustion.
- (Only if sparking and/or clunk sound) Check the voltage on each wire to gas valve assembly (Part #102) and/or the igniter assembly (Part #711). Refer to "Appendix A" in Section C.
 - *No sparking sound >>>> Refer to #1 at "Appendix A" in Section C.
 - *No clunk sound >>>> Refer to #2 at "Appendix A" in Section C.
- Check if there is leaking from the heat exchanger (Part #401).
- Check if there is dust and lint in nozzles of the manifold (Part #102).
- Check the current on the flame rod (Part #108). Refer to #3 at "Appendix A" in Section C.

121: Loss of flame*

- Check the gas supply and inlet gas pressure.
- Check if the Hi-limit switch (Part #412) is functioning properly.
- Check for connection/breakage of wires (Part #413, 708, 709, 711), burn marks on the computer board (Part #701), and/or soot on the flame rod (Part #108). And then if the O.H.C.F (Part #413) has a breakage, **Consult the manufacturer.**
- Check if there is leaking from the heat exchanger (Part #401).
- Check if there is dust and lint in nozzles of the manifold (Part #102).
- Check the current on the flame rod (Part #108). Refer to #3 at "Appendix A" in Section C.

311,321,331,341: Disconnected/short-circuited thermistor*

- Check for connection/breakage of wires and/or debris on the thermistor (Part #407, 408, 411, 715, 718).
- Check the thermistor resistance. Refer to "Appendix D" in Section C.

391: Air-fuel ratio rod failure*

- Check for connection/breakage of wires (Part #709) and/or soot on the flame rod (Part #108).

441: Flow sensor failure (Only Easy-Link & Multi-Unit Systems)

- Check for connection/breakage of wires and/or debris on the flow sensor impeller (Part #402).

<<Unit does not ignite when water goes through the water heater>>

- Refer to "Power supply circuit" and "Water circuit" in this section.
- Check if the inlet water temperature is too high. If it is too close to the set temperature, the water heater won't activate.
- Is the gas supply turned on?

<<The fan motor is still spinning after operation has stopped>>

- This is normal. After operation has stopped, the fan motor keeps running from 15 to 70 seconds in order to re-ignite quickly, as well as purge all the exhaust gas out of the flue.

<<Abnormal sound from water heater>>

- An abnormal sound from the water heaters is caused by not enough air supply or incorrcrct installations. The water heater needs more combustion air. Refer to the "101" error code in the section B.

<<Power supply circuit>>

- Check the power supply, and make sure that the water heater has 120 VAC.
- Is the power switch inside water heater turned on? (Part #706)
- Press the "ON/OFF" button of the built-in controller (the remote controller, if it is installed*) and make sure that the STAND BY LED on the controller is lit. Run the water.
- Check if the green LED on the PCB (Part #701) of the water heater is lit. If so, the power supply circuit of the water heater is under normal condition. Next, refer to "Water circuit" in this section.
- Check the fuse on the surge box (Part #703), and if it has a brown spot, need to replace it.
- If the green LED on the PCB (Part #701) isn't lit, some electrical parts may be broken. **Consult the manufacturer.**

<<Water circuit>>

- Turn on the power button on the built-in controller (the remote controller if it is installed*), and then check if the STAND BY LED will light up.
- Open all hot water faucets, and make sure that there is enough water flow. This water heater needs at least 0.5 GPM (1.9 L/m) water flow (at the default set temperature) to operate.
- Check for reverse connection and cross connection.
- Check to see if the filter on the cold water inlet is clogged or if there is sediment buildup in the filter. (Part #406)
- Check if water ways in the water heater are frozen. If so, thaw them. Refer to the Installation manual to protect your water heater from freezing.
- Check if the inlet water pressure is higher than 40 psi. If it's lower than 40 psi, increase the pressure.
- Check for connections and breakage of wires (Part #402).
- Check if the motor drive of the flow adjustment valve (Part #402) is locked due to scale buildup, and/or water leakage. If so, consult the manufacturer.

*If a remote controller is installed, it will take priority over the built-in controller.

510,551: Abnormal main gas solenoid valve and gas solenoid valve

- Check for connection/breakage of wires (Part #708) and/or burn marks on the computer board (Part #701).
- Reset power supply of the water heater.
- Check the voltage of each valve on the gas valve assembly (Part #102). Refer to "Appendix C" in Section C.

611: Fan motor fault*

- Check for connection/breakage of wires, dust buildup in the fan motor (Part #103) and/or burn marks on the computer board (Part #701).
- Check for frozen/corrosion of connectors of the fan motor (Part #103).
- Check the voltage between blue wire and each wire of the fan motor (Part #103). Refer to "Appendix B" in Section C.

651: Flow adjustment valve fault (Only Easy-Link & Multi-Unit Systems)

- Inspect the flow adjustment valve (Part #402), for connection/breakage of wires, locked motor drive due to scale buildup, and/or water leakage.
- Check the voltage between black wire and red wire. Refer to "Appendix F" in Section C.

661: Bypass valve fault*

- Inspect the bypass valve (Part #403), for connection/breakage of wires, locked motor drive due to scale buildup, and/or water leakage.
- Check the voltage between brown wire and red wire. Refer to "Appendix F" in Section C.

701: Computer board fault*

- Check for connection/breakage of wires (Part #714), and check the resistance between white wire and red wire. Refer to "Appendix A" in Section C.
- Check the outlet thermistor (Part #408) for proper readings as it may need to be cleaned.

711: Gas solenoid valve drive circuit failure*

- Refer to the "111" and "121" error codes in this section.

721: False flame detection*

- Clean the flame rod (Part #108).
- Check if there is leaking from the heat exchanger (Part #401).

741: Miscommunication between water heater and remote controller

- Check the model type of the remote controller. Model No. 100209924 (TM-RE42)
- Inspect the connections between the water heater and remote controller. Refer to the "Temperature Remote Controller" in the Installation manual.
- Check the power supply of the water heater.
- If this error code appears only on the green LED in the PCB (Part #701), check the voltage on the remote controller terminal on the PCB. Refer to "Appendix E" in Section C.
- If this error code appears only on the remote controller, replace the PCB (Part #701).
- If this error code appears on both the PCB (Part #701) and the remote controller, replace the remote controller.

751: Miscommunication between water heater and built-in controller

- Check the power supply of the water heater.
- If this error code appears only on the green LED in the PCB (Part #701), check the voltage on the built-in controller terminal on the PCB. Refer to "Appendix E" in Section C.
- If this error code appears only on the built-in controller, replace the PCB (Part #701).
- If this error code appears on both the PCB (Part #701) and built-in controller (Part #722), replace the built-in controller (Part #722).

761: Miscommunication between Parent unit and Child units for Easy-Link System

- Check if the connections between the parent unit and the child units are correct. Refer to the "Easy-Link system" section in the Installation manual.

941: Abnormal exhaust temperature (Only 540 Indoor)

- Check for connection/breakage of wires, dust buildup in the fan motor (Part #103) and/or burn marks on the computer board (Part #701).
- Check the exhaust thermistor resistance. Refer to "Appendix D" in Section C.

991: Imperfect combustion*

- Refer to the "101" error code in this section.

*These error codes will be cleared when water flow stops in a single unit installation.

C. Wiring diagram and check point of the water heater

The tech should power the heater off and then on to reset the error code.

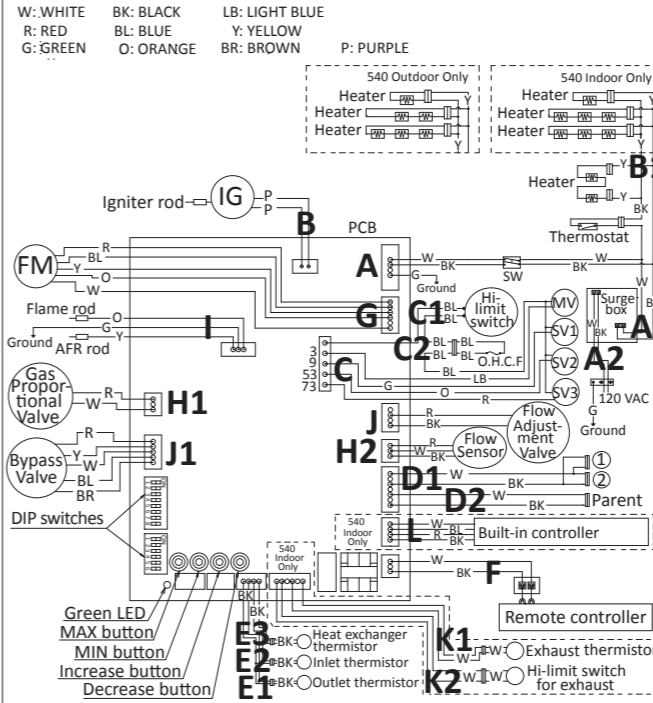

Appendix A (For error code 111)

Check the following points during ignition stage.

- Refer to check point "B" on the wiring diagram above. Check the voltage between purple wires. (Normal: 108 to 132 VAC)
Is the voltage within normal range?
Yes >> Replace the igniter assembly (Part #711).
No >> Go to Next.

- Refer to check points "C" and "H1" on the wiring diagram above. Check the voltages below:
C: Between blue wire and light blue wire (#3). (Normal: 93 to 120 VDC)
C: Between blue wire and orange wire (#53). (Normal: 93 to 120 VDC)
H1: Check the voltage between white wire and red wire. (Normal: 1 to 15 VDC)

- Are these voltages within normal range?**
Yes >> Replace the gas valve assembly (Part #102).
No >> Replace the PCB (Part #701).
- Check the current through the yellow flame rod wire (Part #709). (Normal: more than 5 µA)
Is the current normal when there is a flame?
Yes >> Replace the PCB (Part #701).
No >> Replace the flame rod (Part #108).

Appendix F (For error code 651 and 661)

- Error code 651 : Refer to check point "J" on the wiring diagram above. Check the voltage between black wire and red wire. (Normal: 7 to 16 VDC)
Error code 661 : Refer to check point "J1" on the wiring diagram above. Check the voltage between brown wire and red wire. (Normal: 3 to 11 VDC)
Is the voltage within normal range?
Yes >> Error code 651: Replace the Flow adjustment valve (Part #402). / Error code 661: Replace the Bypass valve (Part #403).
No >> Replace the PCB (Part #701).

D. DIP switch settings on the computer board of the water heater

- Locate the bank of DIP switches at the bottom left of the computer board of the unit.
- Change the DIP switch settings when the power supply is turned off.
- The dark squares indicate the correct DIP switch set positions. **DEFAULT is the factory setting.**

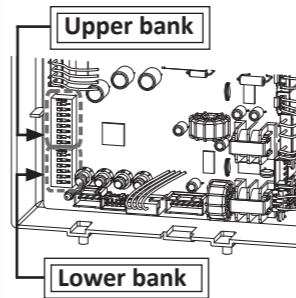

<Upper bank of DIP switches>

Vent settings (Indoor models only)			
	Direct Vent	5 to 20 ft (1.5 to 6.1 m) (DEFAULT)	21 to 40 ft (6.2 to 12.2 m)
	Single Vent	5 to 45 ft (1.5 to 13.7 m) (DEFAULT)	41 to 70 ft (12.3 to 21.3 m)
	4" venting	5 to 50 ft (1.5 to 15.2 m) (DEFAULT)	51 to 100 ft (15.3 to 30.5 m)
		ON OFF 1 2 3 4 5 6 7 8	ON OFF 1 2 3 4 5 6 7 8

Set DIP switches shown in the table above depending on the vent length.

<Lower bank of DIP switches>

Temperature set

120 °F (49 °C)	ON OFF 1 2 3 4 5 6
DEFAULT	OFF 1 2 3 4 5 6
140 °F (60 °C)	ON OFF 1 2 3 4 5 6

Easy-Link System

Parent Unit	ON OFF 1 2 3 4 5 6
Child Unit (DEFAULT)	ON OFF 1 2 3 4 5 6

Single unit is the same as the child unit.

*Factory setting

Gas type*	
Propane	ON OFF 1 2 3 4
Natural Gas	ON OFF 1 2 3 4
Model type*	
Indoor model	ON OFF 1 2 3 4 5
Outdoor model	ON OFF 1 2 3 4 5

Appendix B (For error code 611)

- Refer to check point "G" in the diagram to the left and the following.
- Check the voltage between red wire and blue wire (Normal: 132 to 192 VDC).
 - Check the voltage between yellow wire and blue wire (Normal: 13 to 17 VDC).
 - Check the voltage between orange wire and blue wire (Normal: 2.0 to 6.5 VDC).
- Are all of the voltages within normal range?**
Yes >> Replace the fan motor (Part #103).
No >> Replace the PCB (Part #701).

Appendix C (For error code 510 and 551)

- Refer to check point "C" in the diagram to the left and the following. Check the voltage on each valve on the gas valve assembly.
- Between blue wire and light blue wire (#3) (Normal: 93 to 120 VDC).
 - Between blue wire and green wire (#9) (Normal: 93 to 120 VDC).
 - Between blue wire and orange wire (#53) (Normal: 93 to 120 VDC).
 - Between blue wire and red wire (#73) (Normal: 93 to 120 VDC).
- Are all of the voltages within normal range?**
Yes >> Replace the gas valve assembly (Part #102).
No >> Replace the PCB (Part #701).

Appendix D (For error code 311, 321, 331, 341, and 941)

- Outlet thermistor (Find the marking of No.113 on the connector) Check point "E1"
 - Inlet thermistor (Find the marking of No.42 on the connector) Check point "E2"
 - Heat exchanger thermistor (Find the marking of No.12 on the connector) Check point "E3"
- Check the resistance between black wire and black wire.

Temperature	°F	50	59	68	77	86	95
	°C	10	15	20	25	30	35
Resistance	kΩ	15.4	12.6	10.3	8.5	7.0	5.9

- Exhaust thermistor Check point "K1"

Check the resistance between white wire and white wire.

Temperature	°F	50	59	68	77	86	95
	°C	10	15	20	25	30	35
Resistance	kΩ	19.5	15.9	13.0	10.7	8.9	7.4

- Are all of the check points normal?**
Yes >> Replace the PCB (Part #701).
No >> Replace the thermistor (Part #407, 408, 411, 718).

Appendix E (For error code 741 and 751)

- Error code 741: Refer to check point "F" on the wiring diagram above.
Error code 751 : Refer to check point "L" on the wiring diagram above. Check the voltage on the remote controller and/or built-in controller on the PCB.
- Between black wire and white wire. (Normal: 11 to 25 VDC)
- Is the voltage within normal range?**
Yes >> Replace the remote controller and/or built-in controller.
No >> Replace the PCB (Part #701).

High-altitude function

Indoor model		Outdoor model	
0 to 2,000 ft (0 to 610 m) DEFAULT	ON OFF 1 2 3 4 5 6	0 to 2,000 ft (0 to 610 m) DEFAULT	ON OFF 1 2 3 4 5 6
2,000 to 3,000 ft (611 to 914 m)	ON OFF 1 2 3 4 5 6	2,000 to 4,000 ft (611 to 1,219 m)	ON OFF 1 2 3 4 5 6
3,000 to 5,000 ft (915 to 1,524 m)	ON OFF 1 2 3 4 5 6	4,000 to 6,000 ft (1,220 to 1,829 m)	ON OFF 1 2 3 4 5 6
5,000 to 7,500 ft (1,525 to 2,286 m)	ON OFF 1 2 3 4 5 6		
7,500 to 10,100 ft (2,287 to 3,078 m)	ON OFF 1 2 3 4 5 6		

FM speed is increased automatically.

E. Components diagram / Parts list

Case assembly

Indoor model

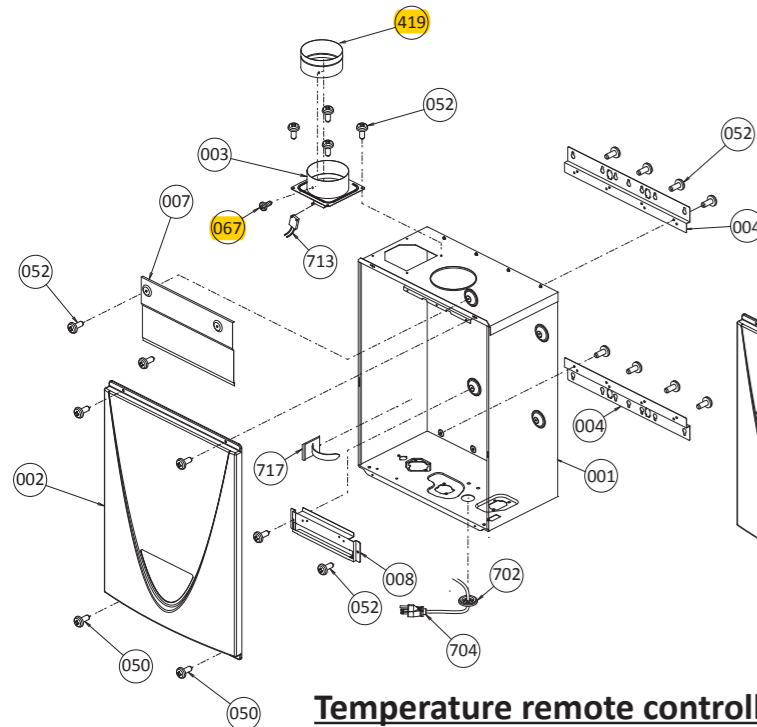

Outdoor model

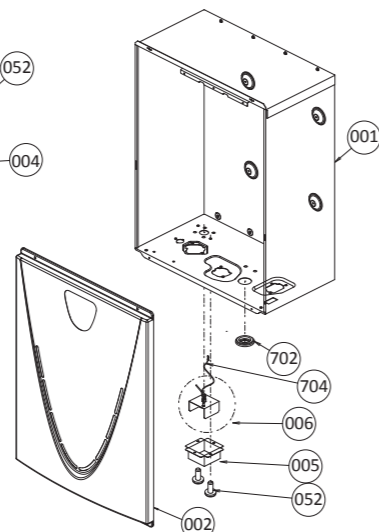

Temperature remote controller

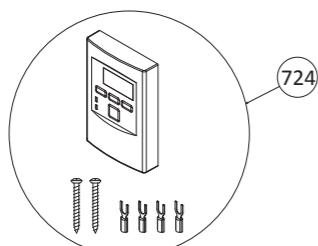

Burner assembly

Burner assembly

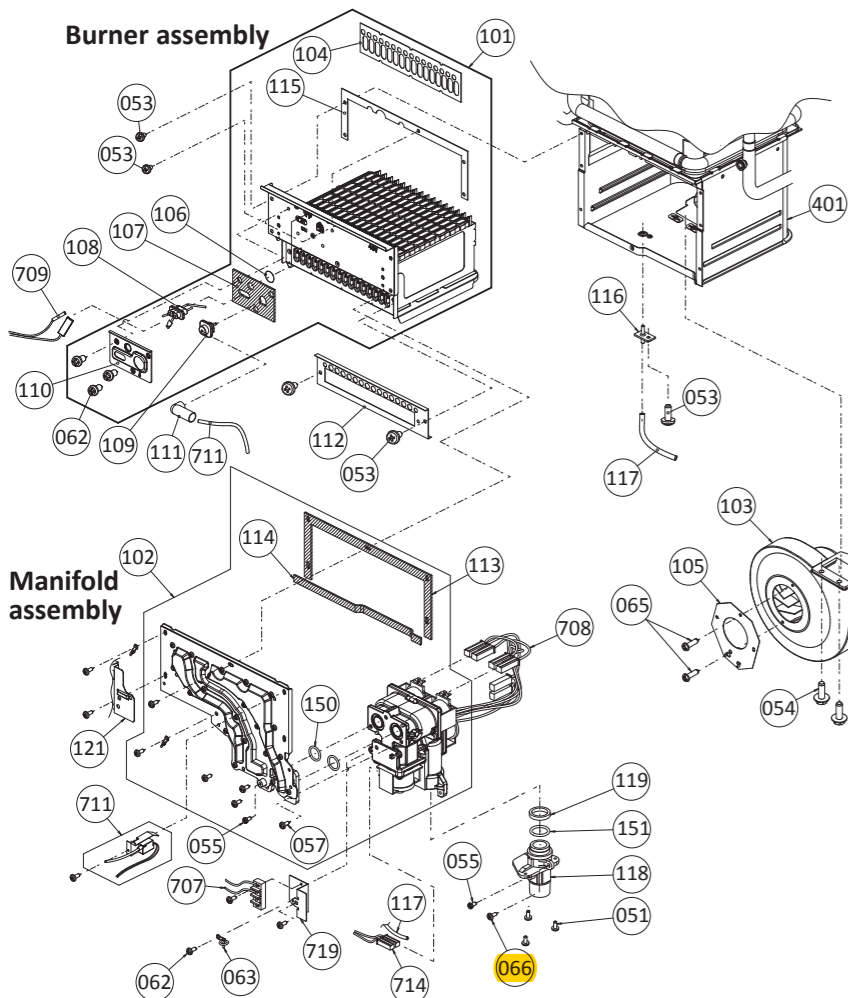

Manifold assembly

Water way assembly

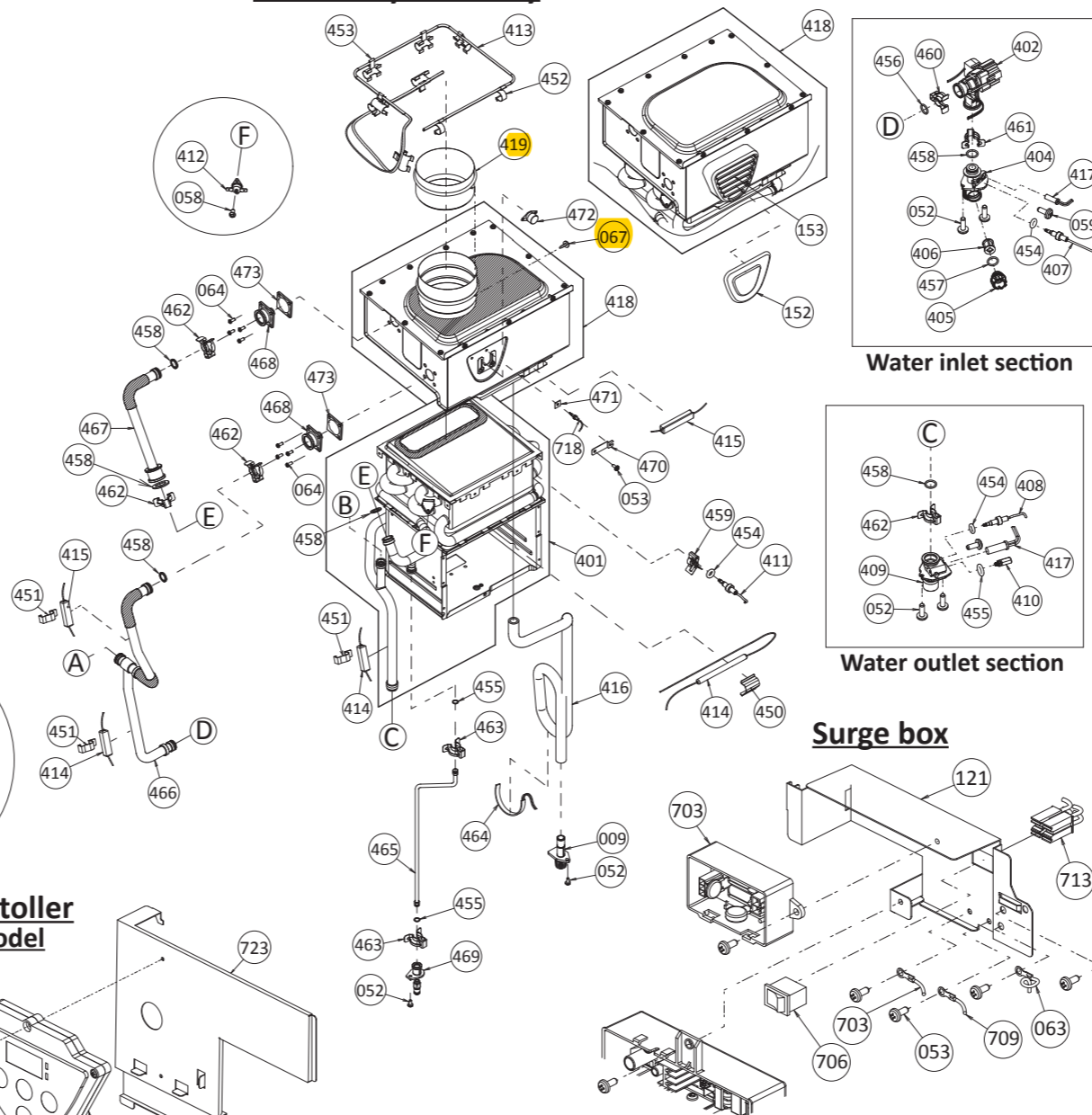

Water inlet section

Water outlet section

Surge box

Bypass section

Built-in controller Indoor model

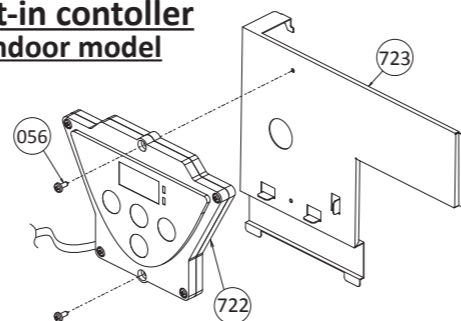

Item #	Part #		Description
	540 model	T-H3 model	
001	N/A	EK159	Case assembly for Indoor models
	N/A	EK164	Case assembly for Outdoor models
002	100074665	EK158	Front cover for Indoor models
	100074666	EK174	Front cover for Outdoor models
003	100074667	EK170	Intake air port assembly
004	N/A	EK162	Bracket
005	100074668	EK190	Junction box
006	100074669	EK171	Power supply cord assembly
007	N/A	EK161	Back guard panel
008	N/A	EK160	Chamber fixing plate
009	100074203	EKH23	Condensate drain port
050	100074210	EW000	Truss screw M4x12 (W/Washer) SUS410
051	100074509	EW001	Truss screw M4x10 (W/Washer)
052	100074211	EW002	Truss screw M4x10 (Coated) SUS3
053	100074245	EW003	Truss screw M4x10 SUS
054	100074510	EW004	Hex head screw M4x12 (W/Washer)
055	100074248	EW005	Hex head screw M4x8 FEZN
056	N/A	EW018	Pan screw M4x20
057	100074385	EKK31	Tap tight screw M4x12 FEZN
058	100074272	EW00A	Pan head screw M3x6 SUS3
059	100074512	EW009	Truss head screw M4x6 SUS3
060	100076269	EKK37	Tap tight screw M4x12
061	N/A	EK191	Screw M3x6 Plus bind FEZN
062	100074244	EW00D	Pan screw M4x8 MFZN
063	100074233	EM167	Wire clamp 60
064	N/A	EK230	Screw M4x10
065	100074514	EW00B	Screw M3x6 SUS3
066	100074247	EW006	Pan screw M4x10
067	N/A	EK739	Pan screw M4x10 for 3" adapter

Item #	Part #		Description
	540 model	T-H3 model	
101	100074670	EK192	Burner assembly
102	100074671	EK181	Manifold with gas valve assembly LP
	100074672	EK182	Manifold with gas valve assembly NA
103	100074606	EK109	Fan motor for Indoor models
	100074228	EKK25	Fan motor for Outdoor models
104	100074216	EKK2X	Burner gasket
105	100074466	EM381	Fan damper for Indoor models
106	100074218	EKK2V	Burner window
107	100074219	EKK2W	Rod holder gasket
108	100074673	EK193	Flame rod
109	100074222	EKK0F	Igniter rod
110	100074221	EKK32	Rod holder
111	100074223	EKN61	Rod cap
112	100074674	EK183	Burner damper LP
	100074675	EK169	Burner damper NA
113	100074229	EKK2Y	Manifold gasket A
114	100074230	EKK2K	Manifold gasket B
115	100074217	EKK0G	Burner holder gasket
116	100074227	EKK2D	Pressure port
117	100074528	EX019	Combustion chamber tube
118	100074616	EK117	Gas inlet
119	100074526	EX00D	Gas inlet ring
121	N/A	EK163	Surge box plate
150	100074533	EZP18	O-ring P18 NBR (Black)
151	100074242	EK042	O-ring P20 NBR (Black)
152	100074678	EK157	Silicon ring for Outdoor models
153	100074679	EK177	Exhaust port for Outdoor models
401	100074699	EK250	Primary heat exchanger assembly
402	100074624	EK129	Flow adjustment valve / Flow sensor
403	100074625	EKD58	Bypass valve
404	100074377	EKK1U	Water inlet
405	100074381	EKK2B	Inlet drain plug
406	100074382	EKK2C	Inlet water filter
407	100074626	EK137	Inlet thermistor

Computer board assembly

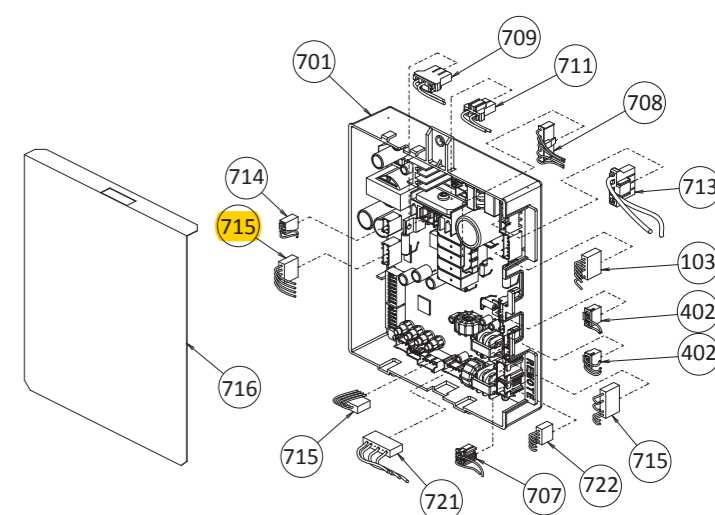

Item #	Part #		Description
	540 model	T-H3 model	
408	100074374	EKK1A	IOutlet thermistor
409	100074681	EK208	Water outlet
410	100074383	EKK2E	Outlet drain plug
411	100074281	EKK2T	Heat exchanger thermistor
412	100074280	EKN34	Hi-Limit switch
413	100074334	EK333	Overheat-cut-off fuse
414	100074682	EK209	Pipe heater
415	100074683	EK210	Inlet heater for Indoor models
	100074684	EK211	Inlet heater for Outdoor models
416	100074685	EK231	Drain tube
417	100074629	EK105	Inlet heater
418	100074700	EK251	Secondary heat exchanger for Indoor models
	100074701	EK256	Secondary heat exchanger for Outdoor models
419	100310706	EK737	3" PVC adapter
450	100074703	EKK27	Pipe heater fixing plate
451	100074310	EK031	Heater fixing plate 16
452	100074251	EKK26	Fuse fixing plate 18
453	100074331	EK029	Fuse fixing plate 14
454	100076303	EZM04	O-ring P4 FKM
455	100076305	EZM06	O-ring P6 FKM
456	100076306	EZM14	O-ring P14 FKM
457	100076307	EZM15	O-ring P15 FKM
458	100076308	EZM16	O-ring P16 FKM
459	100074282	EKH30	Fastener "4-11"
460	100074290	EKK24	Fastener "14-22"
461	100074410	EM192	Fastener "16A"
462	100074389	EKK39	Fastener "16-25A"
463	100074297	EX12K	Fastener "6-15"
464	100074686	EK217	Flat heater
465	100074687	EK218	Drain pipe
466	100074689	EK220	Cold pipe
467	100074690	EK222	Stainless heat exchanger out pipe
468	100074691	EK226	Header connection
469	100074692	EK228	Drain port
470	100074291	EX13H	Thermistor fixing plate
471	100074296	EX13L	Exhaust thermistor gasket
472	100074289	EKH6G	Hi-limit switch for exhaust
473	100074693	EK229	Gasket
701	100074696	EK176	Computer board
702	100076470	EX00B	Rubber grommet
703	100076100	EK280	Surge box
704	100074601	EK146	120 VAC wire for Indoor models
	100074697	EK143	120 VAC wire for Outdoor models
706	100074326	EKK4V	120 VAC Power ON-OFF switch
707	100074650	EK165	Remote controller wire
708	100074651	EK168	Gas valve wire
709	100074652	EK166	Flame rod wire
711	100074640	EK153	Igniter assembly
713	100074655	EK184	Switch wire with thermostat for Indoor models
	100074656	EK185	Switch wire with thermostat for Outdoor models
714	100074657	EK167	Proportional gas valve wire
715	100074658	EK179	24V cables
716	100074375	EKK1M	Computer board cover
717	N/A	EK13C	Cable clamp for Indoor models
718	100074316	EKH6E	Exhaust thermistor for Indoor models
719	100074644	EK152	Remote fixing plate
721	100074659	EK180	Exhaust Hi-limit switch wire
722	100074660	EK173	Built-in controller for Indoor models
723	100074661	EK178	Fixing plate
724	100209924	TM-RE42	Temperature remote controller
N/A	100076516	EKK0J	Communication cable for linking.*

*Refer to p. 9 on the Installation manual.