



LOW LEAD
CONTENT

GAS-FIRED



LISTED

CLASSIFIED



WATER QUALITY

WARNING: If the information in these instructions is not followed exactly, a fire or explosion may result causing property damage, personal injury or death.

- Do not store or use gasoline or other flammable vapors and liquids in the vicinity of this or any other appliance.
- **WHAT TO DO IF YOU SMELL GAS:**
 - Do not try to light any appliance.
 - Do not touch any electrical switch; do not use any phone in your building.
 - Immediately call your gas supplier from a neighbor's phone. Follow the gas supplier's instructions.
 - If you cannot reach your gas supplier, call the fire department.
- Installation and service must be performed by a qualified installer, service agency or the gas supplier.

Thank you for buying this energy efficient water heater. We appreciate your confidence in our products.

**POWER VENT/POWER DIRECT VENT GAS MODELS
WITH DIRECT SPARK IGNITION
MODELS 50/75 GALLON SERIES 400/401
INSTALLATION - OPERATION - SERVICE - MAINTENANCE**



⚠ WARNING

Safety Hazard



Failure to follow these instructions and safety messages could result in death or serious injury.

Read and understand this instruction manual and the safety messages herein before installing, operating or servicing this water heater.

This manual must remain with the water heater.

For Your Safety

**AN ODORANT IS ADDED TO THE GAS USED
BY THIS WATER HEATER.**

PLACE THESE INSTRUCTIONS ADJACENT TO HEATER AND NOTIFY OWNER TO KEEP FOR FUTURE REFERENCE.

KEEP THIS MANUAL IN THE POCKET ON HEATER FOR FUTURE REFERENCE WHENEVER MAINTENANCE ADJUSTMENT OR SERVICE IS REQUIRED.

CONTENTS

APPROVALS	3	Direct Vent Terminal Installation	29
GENERAL SAFETY INFORMATION	3	Direct Vent Air Intake Moisture Protection	30
Precautions	3	Installation Sequence	30
Limiting the Risk of Scalding	3	Vertical Vent Terminal Installation	30
Grounding Instructions	3	Flat Roof Installation	30
Hydrogen Gas Flammable	3	Sidewall Termination direct vent Clearances	32
Important Definitions	4	Sidewall Termination Clearances Other Than Direct Vent	33
Hazard Messages	4	Direct Vent Diagram	34
INTRODUCTION	8	Low Profile Termination Installation	35
Abbreviations Used	8	WATER HEATER INSTALLATION	36
Qualifications	8	Condensate Drain Installation	36
Preparing For The Installation	8	Gas Piping	37
FEATURES AND COMPONENTS	10	Sediment Traps	37
Controls And Switches	12	Electrical Wiring	37
Other Features	13	Dedicated Power Wiring and Breakers	37
INSTALLATION CONSIDERATIONS	14	Leak Detection Module	38
Locating The Water Heater	15	START UP	39
Insulation Blankets	16	Prior to Start up	39
Combustion Air And Ventilation	17	Gas Calibration	40
Unconfined Space	17	Lighting Instructions	41
Unusually Tight Construction	17	TEMPERATURE REGULATION	42
Confined Space	17	Limiting the Risk of Scalding	42
Direct Vent Appliances	17	High Temperature Limit Control	42
Exhaust Fans	17	Thermostat Control	42
Louvers and Grilles	17	High Temperature Applications	43
Fresh Air Openings For Confined Spaces	17	CONTROL SYSTEM OPERATION	44
INSTALLATION REQUIREMENTS	20	Limiting the Risk of Scalding	44
Chemical Vapor Corrosion	20	Wi-Fi	44
Water Piping	20	Lockout Function	44
Power Supply	20	Control System Overview	44
Dedicated Power Wiring and Breakers	20	Control System Navigation	44
Power Fluctuations and Electrical Noise	20	User Settings & Control System Menus	46
Thermostatic Point-of-Use Mixing Valves	21	MAINTENANCE	57
Gas Supply Systems	21	Venting System Maintenance	57
Gas Pressure Requirements	21	Draining and Flushing	57
Supply Gas Regulator	21	Lime Scale Removal	58
Space Heating And Potable Water System	22	Burner Inspection and Maintenance	58
Closed Water Systems	22	Burner Flame Inspection	58
Thermal Expansion	22	Anode Rod Maintenance	59
Temperature-Pressure Relief Valve	23	Temperature-Pressure Relief Valve Test	59
T&P Valve Discharge Pipe Requirements	23	Service	60
Condensate Piping	24	TROUBLESHOOTING	61
Condensate Ph Level	24	Installation Checklist	61
High Altitude Installations	25	Sequence Of Operation	61
Massachusetts Installation Requirements	26	Start Up Conditions	63
VENTING INSTALLATION	27	Operational Conditions	63
Vent Installation Considerations	27	Operational Problems	63
Vent/Intake Material	27	Replacement Parts	64
Polypropylene Installations	28	Fault And Alert Conditions	64
Vent Pipe Termination	28	Checking for Leaks	77
Planning The Vent System	28	Water Leak Detection	77
Installation Of Horizontal Through The Wall Vent System	29	DIAGRAMS	78
Vent Terminal Installation, Sidewall	29	Wiring Diagram	79

APPROVALS



GENERAL SAFETY INFORMATION

PRECAUTIONS

DO NOT USE THIS WATER HEATER IF ANY PART HAS BEEN EXPOSED TO FLOODING OR WATER DAMAGE. Immediately call a qualified service agency to inspect the water heater and to make a determination on what steps should be taken next.

If the unit is exposed to the following, do not operate heater until all corrective steps have been made by a qualified service agency.

1. External fire.
2. Damage.
3. Firing without water.

LIMITING THE RISK OF SCALDING

For a variety of reasons, water heaters can produce water that is much hotter than its temperature setting. Take precautions to prevent this higher temperature water from reaching the water fixtures.

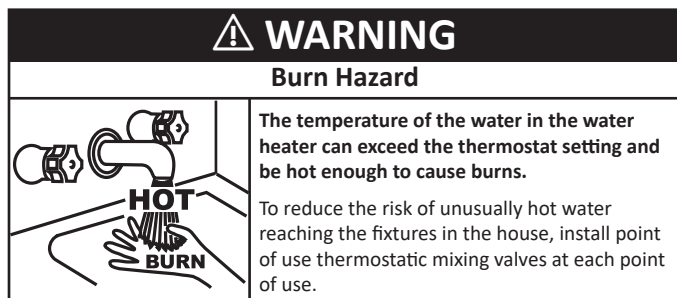

According to a national standard, *Performance Requirements for Water Temperature Limiting Devices (ASSE 1070)* and many local plumbing codes, the water heater's gas control valve should not be used as the sole means to regulate water temperature and avoid scalds.

A properly adjusted thermostatic mixing valve at each point of use allows you to set the tank temperature to a higher setting without increasing risk of scalds. A higher temperature setting allows the tank to provide

much more hot water and can help provide proper water temperatures for appliances such as dishwashers and washing machines.

GROUNDING INSTRUCTIONS

This water heater must be grounded in accordance with the *National Electrical Code* and/or local codes. These codes must be followed in all cases. Failure to ground this water heater properly may also cause erratic control system operation.

This water heater must be connected to a grounded metal, permanent wiring system; or an equipment grounding conductor must be run with the circuit conductors and connected to the equipment grounding terminal or lead on the water heater.

HYDROGEN GAS FLAMMABLE

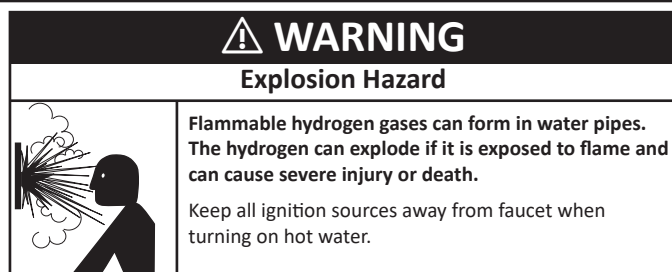

Hydrogen gas can be produced in a hot water system served by this water heater that has not been used for a long period of time (generally two weeks or more). Hydrogen gas is extremely flammable. To reduce the risk of injury under these conditions, it is recommended that a hot water faucet served by this water heater be opened for several minutes before using any electrical appliance connected to the hot water system. If hydrogen is present there will probably be an unusual sound such as air escaping through the pipe as the water begins to flow. **There should be no smoking or open flame near the faucet at the time it is open.**

Verify that the power to the water heater is turned off before performing any service procedures. The Enable/Disable switch on front panel disables the gas valve. Electrical supply must be turned off at circuit breaker serving water heater.

IMPORTANT DEFINITIONS

Qualified Installer: A qualified installer must have ability equivalent to a licensed tradesman in the fields of plumbing, air supply, venting and gas supply, including a thorough understanding of the requirements of the *National Fuel Gas Code, ANSI Z223.1/NFPA 54* as it relates to the installation of gas fired water heaters. The qualified installer must also be familiar with the design features and use of flammable vapor ignition resistant water heaters and have a thorough understanding of this Installation and Operating manual.

Service Agency: A service agency also must have ability equivalent to a licensed tradesman in the fields of plumbing, air supply, venting and gas supply, including a thorough understanding of the requirements of the *National Fuel Gas Code, ANSI Z223.1/NFPA 54* as it relates to the installation of gas fired water heaters. The service agency must also have a thorough understanding of this Installation and Operating manual, and be able to perform repairs strictly in accordance with the service guidelines provided by the manufacturer.

Gas Supplier: The Natural Gas or Propane Utility or service who supplies gas for utilization by the gas burning appliances within this application. The gas supplier typically has responsibility for the inspection and code approval of gas piping up to and including the Natural Gas meter or Propane storage tank of a building. Many gas suppliers also offer service and inspection of appliances within the building.

HAZARD MESSAGES

Your safety and the safety of others is extremely important in the installation, use and servicing of this water heater. Many safety-related messages and instructions have been provided in this manual and on your own water heater to warn you and others of a potential injury hazard. Read and obey all safety messages and instructions throughout this manual. It is very important that the meaning of each safety message is understood by you and others who install, use or service this water heater.

Many safety-related messages and instructions have been provided in this manual and on your own water heater to warn you and others of a potential injury hazard. Read and obey all safety messages and instructions throughout this manual. It is very important that the meaning of each safety message is understood by you and others who install, use, or service this water heater.

	This is the safety alert symbol. It is used to alert you to potential personal injury hazards. Obey all safety messages that follow this symbol to avoid possible injury or death. Keep this manual near the water heater.
-------------------------------------------------------------------------------------	----------------------------------------------------------------------------------------------------------------------------------------------------------------------------------------------------------------------------

⚠ DANGER	DANGER indicated an imminently hazardous situation which, if not avoided, will result in injury or death.
⚠ WARNING	WARNING indicates a potentially hazardous situation which if not avoided could result in injury or death.
⚠ CAUTION	CAUTION indicates a potentially hazardous situation which, if not avoided, could result in minor or moderate injury.
CAUTION	CAUTION used without the safety alert symbol indicates a potentially hazardous situation which, if not avoided could result in property damage

All safety messages will generally tell you about the type of hazard, what can happen if you do not follow the safety message, and how to avoid the risk of injury.

⚠ WARNING	
Safety Hazard	
	<p>Failure to follow these instructions and safety messages could result in death or serious injury.</p> <p>Read and understand this instruction manual and the safety messages herein before installing, operating or servicing this water heater.</p> <p>This manual must remain with the water heater.</p>

⚠ WARNING	
Explosion Hazard	
	<p>Flammable hydrogen gases can form in water pipes. The hydrogen can explode if it is exposed to flame and can cause severe injury or death.</p> <p>Keep all ignition sources away from faucet when turning on hot water.</p>

CAUTION	
Property Damage Hazard	
	<p>Over time, the tank and fittings of the water heater can begin to leak and cause water damage.</p> <ul style="list-style-type: none"> • Locate the water heater near an adequate drain and in an area where water leakage from the heater or connections will not result in damage to the area or the lower floors of the structure. • Install the water heater in a drain pan.

CAUTION	
Property Damage Hazard	
	<p>Avoid water heater damage from pressure fluctuations in closed water systems.</p> <ul style="list-style-type: none"> • Fill tank with water before operating. • Install thermal expansion tank if necessary. • Do not apply heat to cold water inlet. • Contact qualified installer or service agency.

⚠️ WARNING	
Fire or Explosion Hazard	
	<p>Under certain circumstances, the water heater can explode and catch fire, resulting in property damage, personal injury, or death.</p> <p>Do the following to avoid these conditions:</p> <ul style="list-style-type: none"> • Do not store or use gasoline or other flammable vapors and liquids in the vicinity of this or any other appliance. • Avoid all ignition sources if you smell gas. • Do not expose water heater controls to excessive gas pressure. • Use only the gas shown on the water heater rating label. • Maintain required clearances to combustibles. • Keep ignition sources away from faucets after extended periods of non-use.
Read instruction manual before installing, using or servicing water heater.	

⚠️ WARNING	
Breathing Hazard - Carbon Monoxide Gas	
	<ul style="list-style-type: none"> • Install water heater in accordance with the Instruction Manual and NFPA 54 or CAN/CSA-B149.1. • To avoid injury, combustion and ventilation air must be taken from outdoors. • Do not place chemical vapor emitting products near water heater.
Breathing carbon monoxide can cause brain damage or death. Always read and understand instruction manual.	

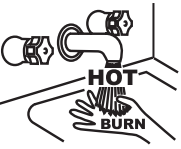
⚠️ DANGER	
Burn Hazard	
	<p>Because of the increased risk from scalding, if you set the water heater's gas control knob higher than 120°F (49°C), install thermostatic point-of-use mixing valves at each point of use. Due to the increased risk of scalding, do not set the temperature of the thermostatic mixing valves above 120°F (49°C).</p>

⚠️ WARNING	
Toxic Chemical Hazard	
	<p>Connecting the water heater to a non-potable water system might result in chemical or biological contamination of the water heater.</p> <p>Do not connect the water heater to a non-potable water system.</p>

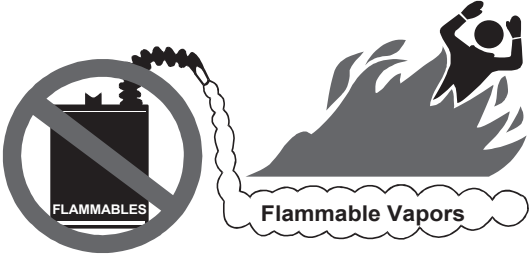
⚠️ DANGER	
Fire or Explosion Hazard	
	
<p>Vapors from flammable liquids may explode and catch fire causing death or severe burns.</p> <p>Do not use or store flammable products, such as gasoline, solvents, or adhesives in the same room or area near the water heater.</p> <p>Keep flammable products:</p> <ol style="list-style-type: none"> 1. Far away from heater. 2. In approved containers. 3. Tightly closed and 4. Out of children's reach 	<p>Water heater has a main burner and ignition device. The ignition device:</p> <ol style="list-style-type: none"> 1. Can come on at any time. 2. Will ignite flammable vapors. <p>Vapors:</p> <ol style="list-style-type: none"> 1. Cannot be seen. 2. Are Heavier than air. 3. Go a long way on the floor. 4. Can be carried from other rooms to the ignition device by air currents.
<p>Installation:</p> <p>Do not install the water heater where flammable products will be stored or used unless the main burner and igniter are at least 18" (457 cm) above the floor. This will reduce, but not eliminate the risk of vapors being ignited by the main burner or hot surface igniter.</p>	

⚠️ WARNING	
Fire and Explosion Hazard	
	<p>Read the instruction manual before installing, using, or servicing the water heater.</p> <ul style="list-style-type: none"> • Improper use can result in fire or explosion. • Maintain required clearances to combustibles.

⚠️ WARNING	
Breathing Hazard - Carbon Monoxide Gas	
	<ul style="list-style-type: none"> • Do not obstruct water heater air intake with insulating blanket. • Gas and carbon monoxide detectors are available. • Install water heater in accordance with the instruction manual.
Breathing carbon monoxide can cause brain damage or death. Always read and understand instruction manual.	

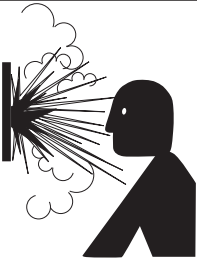
⚠ WARNING	
Explosion Hazard	
	<p>Normal operation of the water heater can cause it to become sufficiently over-heated and/or over-pressurized that it can explode, resulting in property damage, sever injury, or death.</p> <p>To avoid this hazard, you must install a properly-sized temperature-pressure relief valve in opening provided.</p> <ul style="list-style-type: none"> • The temperature-pressure relief valve must comply with ANSI Z21.22-CSA 4.4 and ASME code. • Do not plug, block, or cap the discharge line.

⚠ CAUTION	
Property Damage Hazard	
	<p>While the water heater is in routine operation, it can release hot water from the temperature-pressure relief valve discharge pipe in quantities that could cause damage to the surroundings.</p> <p>Locate the water heater near an adequate drain and in an area where water from the temperature-pressure relief valve discharge pipe will not result in damage to the area or the lower floors of the structure.</p>

⚠ DANGER	
Burn Hazard	
	<p>The discharge water from the temperature-pressure relief valve is hot enough to cause burns.</p> <p>Keep clear of the temperature-pressure relief valve discharge outlet.</p>

⚠ WARNING	
Breathing Hazard - Carbon Monoxide Gas	
	<ul style="list-style-type: none"> • Special considerations must be taken with installations above 10,100 (3,078 meters). • Please contact an A. O. Smith qualified service agent to obtain the proper setup and instructions before lighting. • Failure to implement the proper setup will result in improper and inefficient operation of the appliance, resulting in production of increased levels of carbon monoxide gas in excess of the safe limits which could result in serious personal injury or death. <p>Breathing carbon monoxide can cause brain damage or death. Always read and understand instruction manual.</p>

⚠ WARNING	
Breathing Hazard - Carbon Monoxide Gas	
	<ul style="list-style-type: none"> • Install vent system in accordance with codes. • Do not operate water heater if any part has been exposed to flooding or water damage. • High altitude models should be installed at elevations above 5,300 feet (1,615 m). For operation above 10,100 feet (3,079 m), a high altitude orifice must be installed. • Do not operate if soot buildup is present. • Do not obstruct water heater air intake with insulating jacket. • Do not place chemical vapor emitting products near water heater. • Gas and carbon monoxide detectors are available. • No vent damper installation is compatible with this power vented water heater. • Do NOT elevate any portion of the field supplied drain line beyond the 1/2" adapter above the adapter. This must be true for the entire length of the drain line including the exit into an appropriate drain. • Condensate lines must be free and clear of debris and must not allow back flow through the hose. The condensate lines must be able to flow freely to an appropriate drain. • Do not allow condensate lines to become crimped closed. • Analyze the entire vent system to make sure that condensate will not become trapped in a section of vent pipe and therefore reduce the open cross sectional area of the vent. <p>Breathing carbon monoxide can cause brain damage or death. Always read and understand instruction manual.</p>

⚠ WARNING	
Fire and Explosion Hazard	
	<ul style="list-style-type: none"> • Contaminants in gas lines can cause fire or explosions. • Clean all gas piping before installation. • Install drip leg in accordance with NFPA 54 or CSA-B1491.

⚠ WARNING	
Fire and Explosion Hazard	
	<p>Gas piping can leak gas from fittings and connections if it is not sealed properly. Gas leaks can cause fires and explosions resulting in severe injury or death.</p> <ul style="list-style-type: none"> • Use joint compound or thread sealer tape compatible with the type of gas you are using. • Leak test all gas connections before placing the water heater in operation. • Disconnect gas piping at main gas shutoff valve before leak testing. • Install sediment trap in accordance with NFPA 54 or CAN/CSA B149.1.

⚠ WARNING	
Fire and Explosion Hazard	
	<p>An improper field conversion from one type of gas to another could cause potentially dangerous conditions that may cause an explosion or fire resulting in property damage, bodily injury or death.</p> <p>Do not attempt to convert a water heater without consulting A. O. Smith.</p>

⚠ WARNING	
Breathing Hazard - Carbon Monoxide Gas	
	<ul style="list-style-type: none"> • Flue gases may escape if vent pipe is not connected. • Be alert for obstructed, sooted, or deteriorated vent system to avoid serious injury or death. • Do not store corrosive chemicals in the vicinity of the water heater. • Chemical corrosion of the flue and vent system can cause serious injury or death. • Analyze the entire vent system to make sure that condensate will not become trapped in a section of vent pipe and therefore reduce the open cross sectional area of the vent.
<p>Breathing carbon monoxide can cause brain damage or death. Always read and understand instruction manual.</p>	

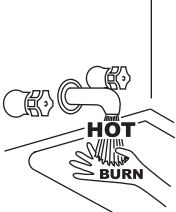
⚠ CAUTION	
Burn Hazard	
	<ul style="list-style-type: none"> • The combustion chamber and burner sleeve and housing become very hot during operation. • Do not reach into the burner housing or combustion chamber if the water heater is still hot. • Allow the water heater to cool and always use gloves when handling the main burner.

⚠ WARNING	
Electrical Shock Hazard	
	<p>Servicing this water heater exposes you to electrified components that can cause severe injury or death if you touch them.</p> <ul style="list-style-type: none"> • Turn off power at the branch circuit breaker serving the water heater before performing any service. • Label all wires prior to disconnecting when performing service. Wiring errors can cause improper and dangerous operation. • Verify proper operation after servicing.

⚠ WARNING	
Safety Hazard	
	<p>Jumping out control circuits or components can result in property damage, personal injury or death.</p> <ul style="list-style-type: none"> • Service should only be performed by a qualified service technician using proper test equipment. • Altering the water heater controls and/or wiring in any way could result in permanent damage to the controls or water heater and is not covered under the limited warranty. • Any bypass or alteration of the water heater controls and/or wiring will result in voiding the appliance warranty.

INTRODUCTION

Thank You for purchasing this water heater. Properly installed and maintained, it should give you years of trouble free service.

ABBREVIATIONS USED

Abbreviations found in this Instruction Manual include :

- ANSI - American National Standards Institute
- ASME - American Society of Mechanical Engineers
- AHRI - Air-Conditioning, Heating and Refrigeration Institute
- ASSE - Performance Requirements for Water Temperature Limiting Devices
- NEC - National Electrical Code
- NFPA - National Fire Protection Association
- UL - Underwriters Laboratory
- CSA - Canadian Standards Association

QUALIFICATIONS

Qualified Installer or Service Agency

Installation and service of this water heater requires ability equivalent to that of a Qualified Agency (as defined by ANSI below) in the field involved. Installation skills such as plumbing, air supply, venting, gas supply and electrical supply are required in addition to electrical testing skills when performing service.

ANSI Z223.1 2006 Sec. 3.3.83: “Qualified Agency” - “Any individual, firm, corporation or company that either in person or through a representative is engaged in and is responsible for (a) the installation, testing or replacement of gas piping or (b) the connection, installation, testing, repair or servicing of appliances and equipment; that is experienced in such work; that is familiar with all precautions required; and that has complied with all the requirements of the authority having jurisdiction.”

If you are not qualified (as defined by *ANSI* above) and licensed or certified as required by the authority having jurisdiction to perform a given task do not attempt to perform any of the procedures described in this manual. If you do not understand the instructions given in this manual do not attempt to perform any procedures outlined in this manual.

PREPARING FOR THE INSTALLATION

1. Read the entire manual before attempting to install or operate the water heater. Pay close attention to the **General Safety Information** (page 3). If you don't follow the safety rules, the water heater may not operate safely. It could cause property damage, injury and/or death.
2. This manual contains instructions for the installation, operation, and maintenance of the water heater. It also contains warnings throughout the manual that you must read and be aware of. All warnings and all instructions are essential to the proper operation of the water heater and your safety.

Detailed installation diagrams are also found in this manual. These

diagrams will serve to provide the installer with a reference. It is essential that all venting, water piping, gas piping and wiring be installed as shown.

3. Particular attention should be given to the installation of thermometers at the locations indicated in the piping diagrams as these are necessary for checking the operation of the water heater.
4. The principal components of the water heater are identified in Features And Components on Page 10 & Page 11 in this manual. Use this reference to locate and identify various components on the water heater.
5. See the **Installation Checklist** (page 61) and **Troubleshooting** (page 61). By using this checklist the user may be able to make minor operational adjustments and avoid unnecessary service calls. However, service and diagnostic procedures should only be performed by a Qualified Service Agency.
Note: Costs to correct installation errors are not covered.
6. Be sure to turn off power when working on or near the electrical system of the water heater. Never touch electrical components with wet hands or when standing in water.
7. The installation must conform to all instructions contained in this manual and the local code authority having jurisdiction. These shall be carefully followed in all cases. Authorities having jurisdiction should be consulted before installation begins if there are any questions regarding compliance with local, state or national codes.
8. In the absence of local codes, the installation must comply with the current editions of the **National Fuel Gas Code, ANSI Z223.1/NFPA 54** and the **National Electrical Code, NFPA 70** or **CAN/CSA-B149.1**, the **Natural Gas and Propane Installation Code** and **CSA C22.1**, the **Canadian Electrical Code**. All documents are available from the Canadian Standards Association, 8501 East Pleasant Valley Road, Cleveland, OH 44131. NFPA documents are also available from the National Fire Protection Association, 1 Batterymarch Park, Quincy, MA 02269.
9. The water heater, when installed, must be electrically grounded in accordance with the local codes or in the absence of local codes: current edition of the **Canadian Electrical Code CSA C22.1, or Part I "National Electrical Code", NFPA 70**.
10. If after reading this manual you have any questions or do not understand any portion of the instructions, call the toll free number found on the warranty sheet provided with the water heater. In order to expedite your request, please have the full Model, Serial and Series number of the water heater you are working with available for the technician. This information is located on the water heater's rating plate.
11. Carefully plan the placement of the water heater. Examine the location to ensure that it complies with the requirements in **Locating The Water Heater** (page 15).

12. For installation in California this water heater must be braced or anchored to avoid falling or moving during an earthquake. See instructions for correct installation procedures. Instructions may be obtained from California Office of the State Architect, 1102 Q Street, Suite 5100, Sacramento, CA 95811.
13. Massachusetts Code requires this water heater to be installed in accordance with *Massachusetts 248-CMR 2.00: State Plumbing Code* and *248-CMR 5*. See *Massachusetts Installation Requirements* (page 26).

Recommended Accessories:

- A metal drain pan.
- Automatic water shut-off device.
- Pressure Reducing Valve.
- Thermal Expansion Tank.
- Thermostatic mixing valves at each point of use.
- Fuel gas and carbon monoxide detector.

FEATURES AND COMPONENTS

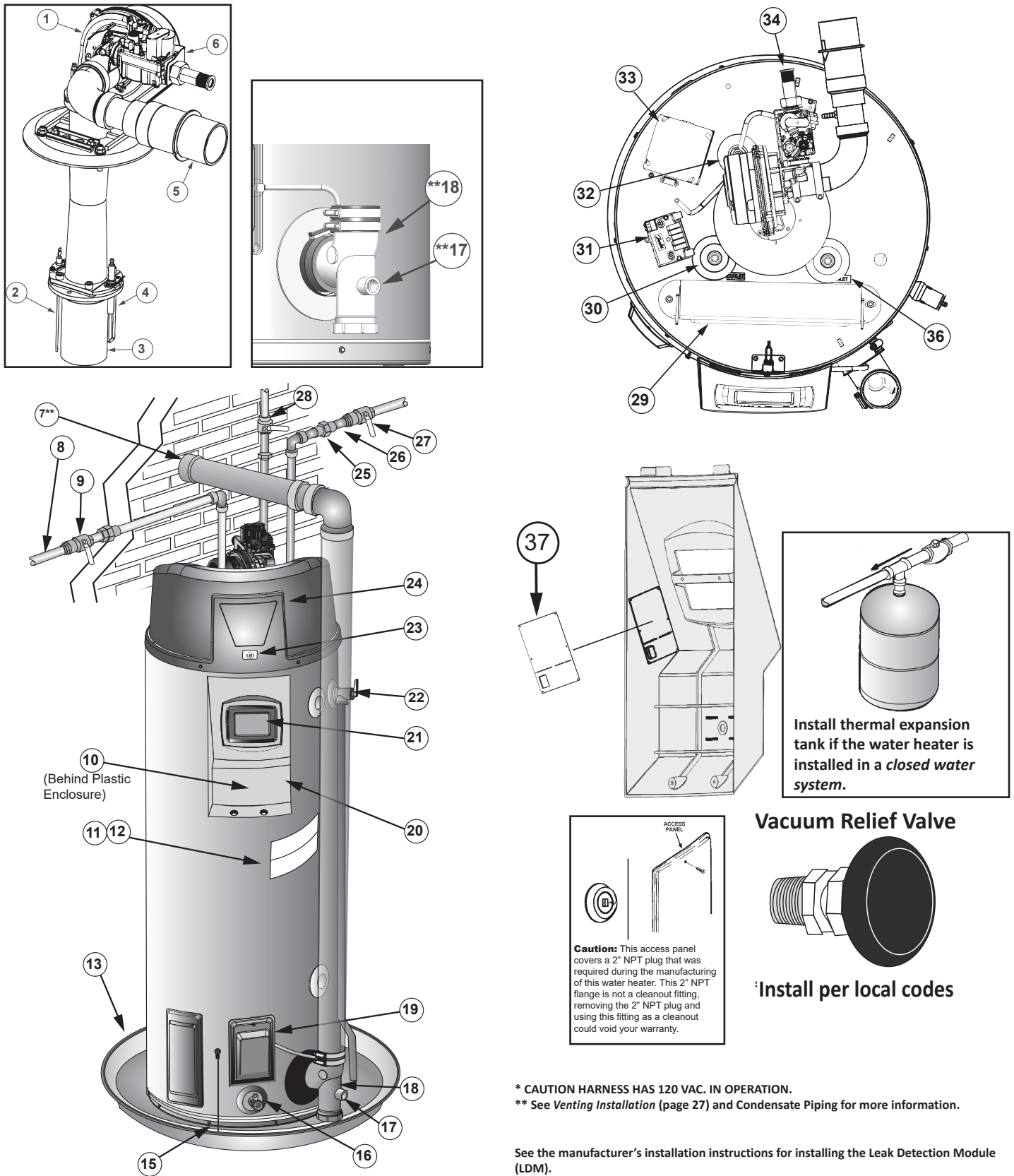

Figure 1. 50-Gallon Unit

* CAUTION HARNESS HAS 120 VAC. IN OPERATION.

** See *Venting Installation* (page 27) and *Condensate Piping* for more information.

See the manufacturer's installation instructions for installing the Leak Detection Module (LDM).

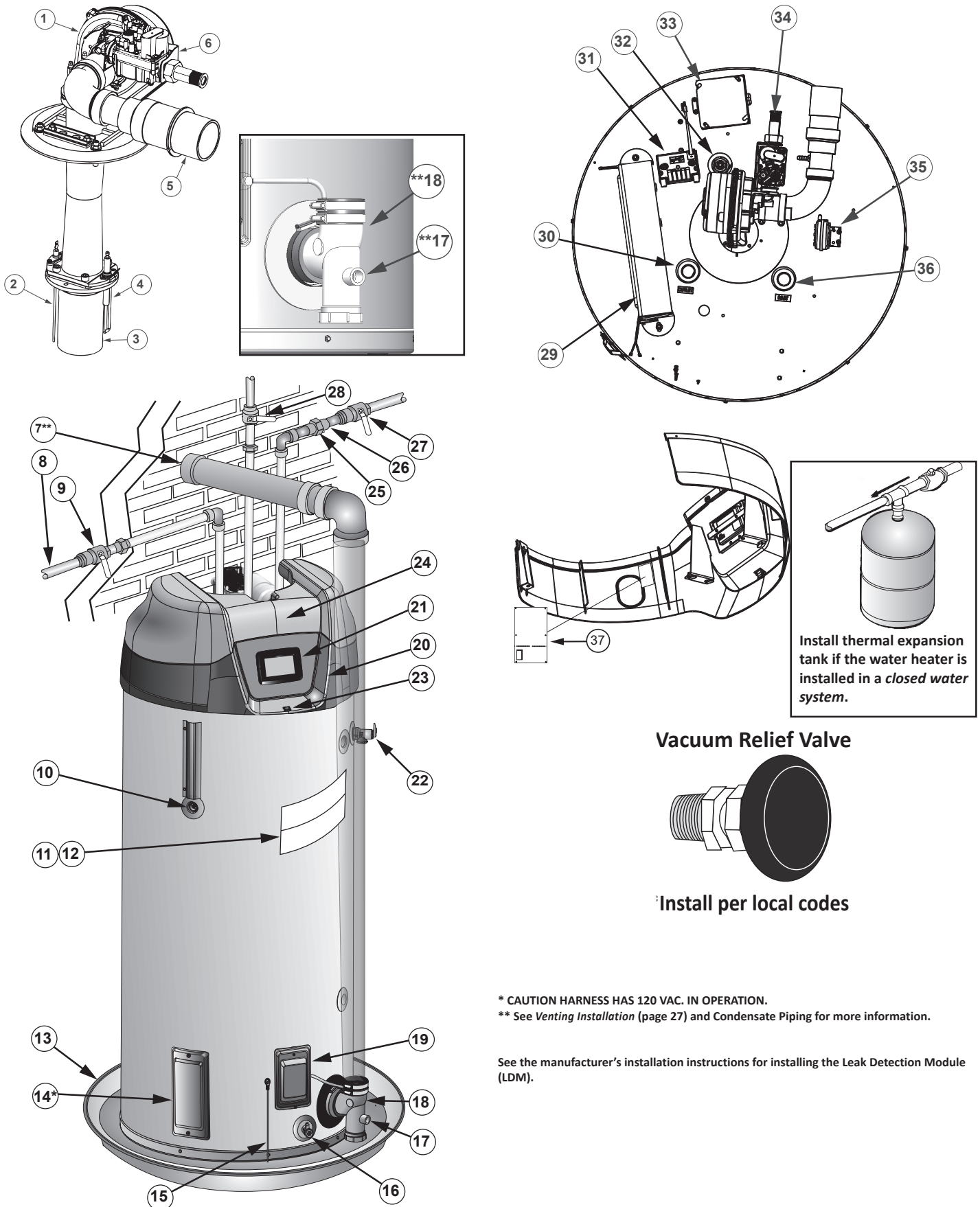

Figure 2. 75-Gallon Unit

* CAUTION HARNESS HAS 120 VAC. IN OPERATION.

** See *Venting Installation* (page 27) and *Condensate Piping* for more information.

See the manufacturer's installation instructions for installing the Leak Detection Module (LDM).

- | | | |
|---------------------------------------------|----------------------------------------|----------------------------------------------------|
| 1. Blower Assembly | 14. Cleanout Access Door | 27. Cold Water Shutoff Valve (field-supplied) |
| 2. Flame Sensor | 15. Leak Detection Module | 28. Main Manual Gas Shutoff Valve (field-supplied) |
| 3. Burner Assembly | 16. Drain Valve | 29. Control Board Enclosure |
| 4. Igniter Assembly | 17. **Condensate Drain Outlet | 30. Hot Water Outlet |
| 5. Intake-Air Fitting | 18. **Exhaust Elbow Assembly | 31. Spark Igniter Transformer |
| 6. Gas Control Valve Assembly | 19. Blocked Outlet Switch/ Access Door | 32. Powered Anode Rod |
| 7. **Vent Terminal | 20. Display Enclosure | 33. Junction Box |
| 8. Hot Water Outlet | 21. UIM (user interface module) | 34. Gas Supply Connection |
| 9. Hot Water Shutoff Valve (field-supplied) | 22. T/P Relief Valve | 35. Blocked Inlet Switch |
| 10. Temperature Probe | 23. Enable / Disable Switch | 36. Cold Water Inlet (field-supplied) |
| 11. Rating Plate | 24. Top Plastic Enclosure | 37. Flexible Memory Module (FMM) |
| 12. Labels | 25. Union (field-supplied) | |
| 13. Drain Pan | 26. Cold Water Inlet | |

Table 1. Recovery Capacities															
Input		Recovery Capacities													
Rating (Btu/hr)	Rating (kW)	Temp. Rise	F	30	40	50	60	70	80	90	100	110	120	130	140
			C	17	22	28	33	39	44	50	56	61	67	72	78
100,000	29.3	GPH		387	291	233	194	166	145	129	116	106	97	90	83
		LPH		1465	1102	882	734	628	549	488	439	401	367	341	314

Recovery capacity based on 96% thermal efficiency.

Table 2. Capacity, Gas And Electrical Characteristics								
Nominal Capacity		Rated Capacity		*Manifold Pressure			Electrical Characteristics	
U.S. Gals.	Liters	U.S. Gals.	Liters	Gas Type	"WC	kPA	Volts/Hz	Amperes
50	189	49	186	Nat./LP	0	0	120/60	<5
75	284	74	280	Nat./LP	0	0	120/60	<5

*The manifold pressure is the factory setting and is not adjustable. A negative pressure will be seen with just the blower running without the Gas Control Valve open.
 All models - Maximum Supply Pressure: 14 inches W.C. (3.48 kPa)
 Minimum Supply Pressure for Natural Gas: 3.50 inches W.C. (.87 kPa)
 Minimum Supply Pressure for Propane Gas: 8.00 inches W.C. (1.99 kPa)
 Minimum pressure must be maintained under both load and no load (dynamic and static) conditions.

CONTROLS AND SWITCHES

This model is provided with two pressure switches. These switches are essential to the safe and proper operation of the unit. The controller is set up to shut the unit down whenever there is a failure of either of the switches. It is important to understand the purpose of both switches.

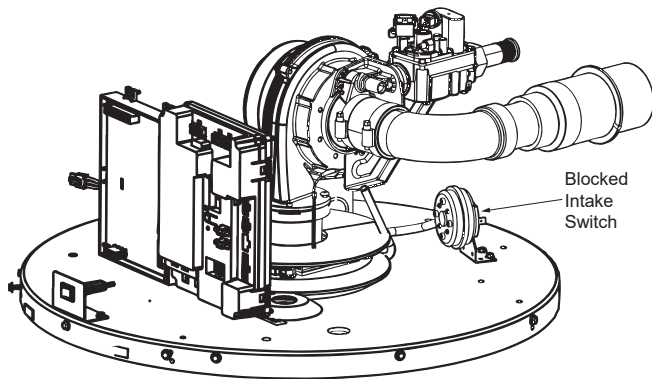

Figure 3. Blocked Intake Switch on 50 Gallon Unit

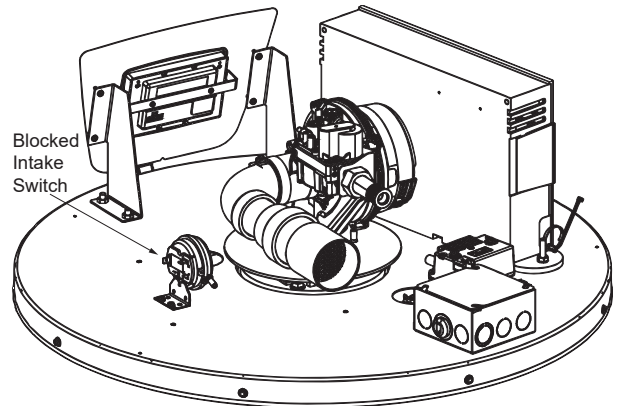

Figure 4. Blocked Intake Switch on 75 Gallon Unit

Blocked Outlet Switch

The Blocked Exhaust Switch is set up to shut the unit off when a build-up of positive pressure in the exhaust vent pipe occurs. This switch is a positive pressure switch that requires an increase in pressure to change the electrical contacts from normally closed to open. When this switch prevents the unit from igniting, most likely the exhaust is blocked by some means. Check to see if the condensate is allowed to flow freely from the exhaust elbow and for obstructions in the exhaust venting and exhaust vent

terminal. Also verify that the vent length does not exceed the maximum allowed as shown in the Vent Section of this manual.

Blocked Intake Switch

The Blocked Intake Switch is set up to shut the unit off when a build-up of negative pressure in the intake air pipe occurs. This switch is a negative pressure switch that requires an increase in negative pressure to change the electrical contacts from normally closed to open. The switch is connected to the pressure tap on the PVC pipe connected to the inlet of the blower. When this switch prevents the unit from igniting, most likely the intake is blocked. Verify that the screen on the intake air connection (conventional vent), the intake air pipe and termination (direct vent installations) are free of obstructions that may prevent air from entering the unit. Ensure the screen on intake air connection has been removed on direct vent installations. See **Figure 17** (page 29). Also verify the intake air pipe length does not exceed the maximum allowed as shown in **Venting Installation** (page 27).

Water Heating Enable/Disable Switch

Important: The Enable/Disable switch listed in this manual is **NOT** an “on/off” switch and does not disconnect 120 volt power to the Control Board Enclosure and other heater components.

Water Heater’s Enable/Disable Switch. When in the “Disabled” position the switch removes electrical power from the gas valve so that water heating is disabled. The display, CSC, TRC, and other electrical components will still be energized and the display will read “Water Heating Disabled”.

OTHER FEATURES

Spark Igniter - The Spark Igniter is a device that ignites the main burner by spark. When high voltage is applied to the igniter, spark is generated to ignite the main burner.

NFC Board - The Near Field Communication (NFC) Board is located inside the plastic display enclosure. The NFC Board enables an NFC device to communicate information with the heater. **DO NOT REMOVE OR DAMAGE THE NFC BOARD.**

Powered Anode Rod - The models covered in this manual are equipped with a powered (non-sacrificial) anode rod. Protective current is fed by the control system to the titanium electrode at the end of the anode rod. This current flows through the water to the conductive surfaces inside the storage tank which diminishes the corrosive effect of water when it comes in contact with steel.

Flame Sensor - The control system monitors the flame sensor to confirm a flame is present at the main burner. If a flame is not verified during the ignition trial period, the control system will immediately deenergize the gas valve.

Gas Valve - This heater is equipped with an adaptive gas valve system with a motor driven throttle suitable for natural or propane. It is controlled by the CSC in conjunction with the TRC.

Control Board Enclosure - This enclosure houses the control system’s temperature regulation control (TRC), combustion and safety control (CSC).

INSTALLATION CONSIDERATIONS

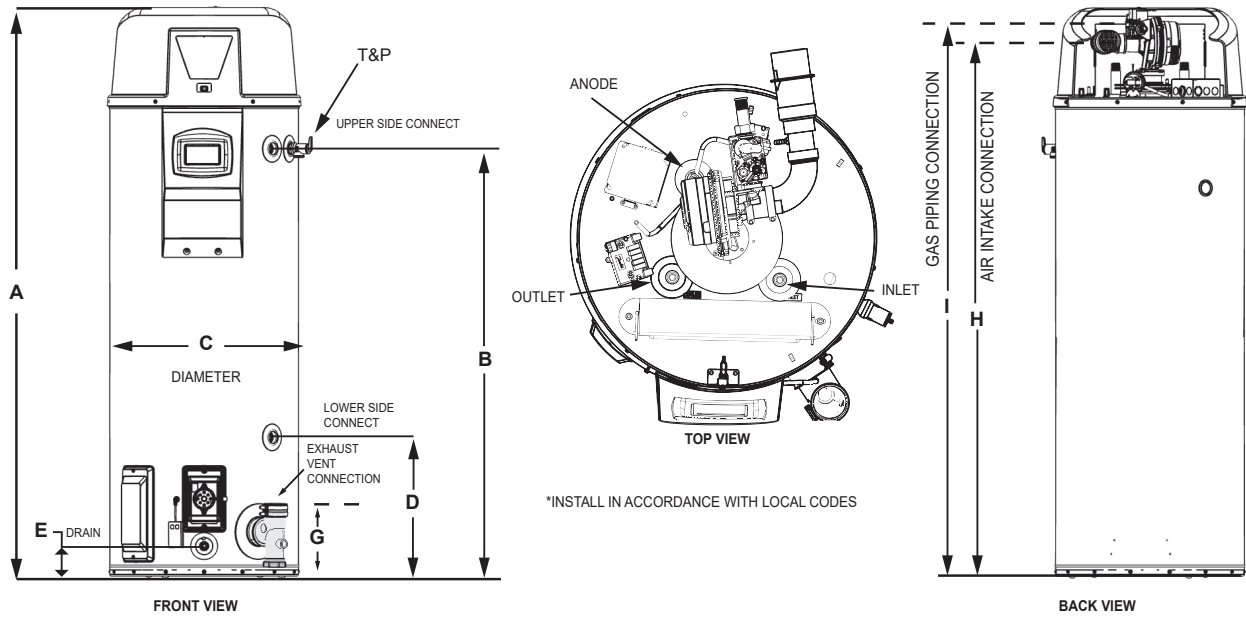

Figure 5. Rough In Dimensions: 50 Gallon Unit

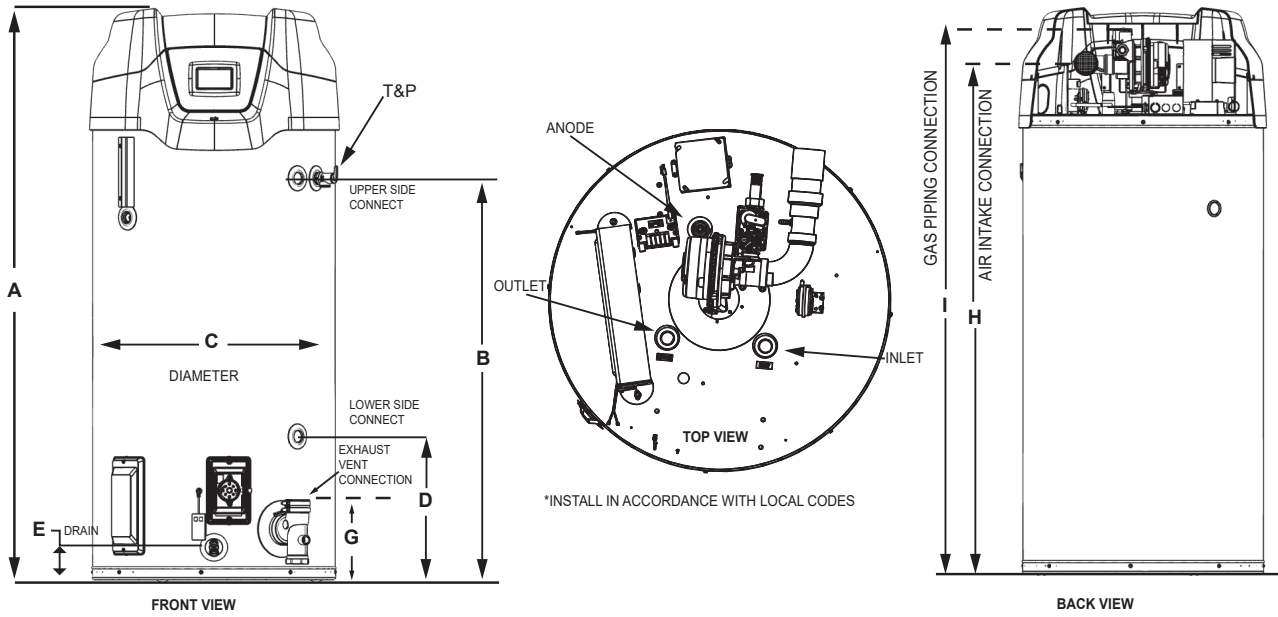



Figure 6. Rough In Dimensions: 75 Gallon Unit

Table 3. Rough-In-Dimensions										
Model	Units	A	B	C	D	E	F	G	H	I
50G	Inches	66 3/4	49 1/4	22	15 3/4	3	8	8	62	65
	cm	169.5	125.09	55.88	40.00	7.62	20.32	20.32	157.48	165.1
75G	Inches	65 1/4	45 5/8	27 3/4	16	3 3/4	8	8	59	60
	cm	165.7	115.9	70.5	40.6	9.4	20.3	20.1	145.7	149.8

Top Inlet and Outlet: 50G - 3/4" NPT; 75G - 1" NPT
 Side Inlet and Outlet: 3/4" NPT
 Gas Inlet: 1/2" NPT
 Condensate drain outlet: 1/2" NPT

LOCATING THE WATER HEATER

Carefully choose a location for the new water heater. The placement is a very important consideration for the safety of the occupants in the building and for the most economical use of the water heater.

CAUTION	
Property Damage Hazard	
	<p>Over time, the tank and fittings of the water heater can begin to leak and cause water damage.</p> <ul style="list-style-type: none"> • Locate the water heater near an adequate drain and in an area where water leakage from the heater or connections will not result in damage to the area or the lower floors of the structure. • Install the water heater in a drain pan.

Whether replacing an existing water heater or installing the water heater in a new location observe the following critical points:

1. The water heater must be located indoors.
2. The water heater must not be located in an area where it will be subject to freezing temperatures.
3. Locate the water heater so it is protected and not subject to physical damage by a moving vehicle.
4. Locate the water heater on a level surface.
5. Locate the water heater near a floor drain. The water heater should be located in an area where leakage of the tank or connections will not result in damage to the area adjacent to the water heater or to lower floors of the structure. When such locations cannot be avoided, it is recommended that a metal drain pan, piped to adequate drain, be installed under the water heater. Drain pan should be fabricated with sides at least 2" deep with diameter at least 2" greater than diameter of heater.
6. Locate the water heater close to the point of major hot water usage.
7. Locate the water heater close to a 120 VAC power supply. See **Power Supply** (page 20) for requirements.
8. Locate the water heater where an adequate supply of fresh air for combustion and ventilation can be obtained. See **Combustion Air And Ventilation** (page 17) and **Venting Installation** (page 27).
9. Locate the water heater where the vent and intake air piping, when installed, will remain within the maximum equivalent lengths allowed. See **Venting Installation** (page 27).
10. Do not locate the water heater where noise (such as the Combustion Blower) during normal operation will be objectionable in adjacent areas.
11. Do not locate the water heater where the subsequent installation of the vent (exhaust) or intake air terminations would be objectionable due to noise at the termination(s). This includes locations close to or across from windows and doors. See **Venting Installation** (page 27).

Do not locate water heater in areas where flammable liquids (vapors) are likely to be present or stored (garages, storage and utility areas, etc.): Flammable liquids (such as gasoline, solvents, propane (LP or butane, etc.) and other substances (such as adhesives, etc.) emit flammable vapors which can be ignited by a gas water heater's ignition device or main burner. The resulting flashback and fire can cause death or serious burns to anyone in the area.

WARNING	
Fire or Explosion Hazard	
	<p>Under certain circumstances, the water heater can explode and catch fire, resulting in property damage, personal injury, or death.</p> <p>Do the following to avoid these conditions:</p> <ul style="list-style-type: none"> • Do not store or use gasoline or other flammable vapors and liquids in the vicinity of this or any other appliance. • Avoid all ignition sources if you smell gas. • Do not expose water heater controls to excessive gas pressure. • Use only the gas shown on the water heater rating label. • Maintain required clearances to combustibles. • Keep ignition sources away from faucets after extended periods of non-use.
<p>Read instruction manual before installing, using or servicing water heater.</p>	

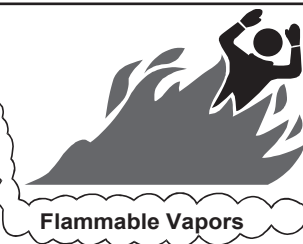
⚠ DANGER	
Fire or Explosion Hazard	
	
<p>⚠ Vapors from flammable liquids may explode and catch fire causing death or severe burns.</p> <p>Do not use or store flammable products, such as gasoline, solvents, or adhesives in the same room or area near the water heater.</p> <p>Keep flammable products:</p> <ol style="list-style-type: none"> 1. Far away from heater. 2. In approved containers. 3. Tightly closed and 4. Out of children's reach 	<p>Water heater has a main burner and ignition device. The ignition device:</p> <ol style="list-style-type: none"> 1. Can come on at any time. 2. Will ignite flammable vapors. <p>Vapors:</p> <ol style="list-style-type: none"> 1. Cannot be seen. 2. Are Heavier than air. 3. Go a long way on the floor. 4. Can be carried from other rooms to the ignition device by air currents.
<p>Installation:</p> <p>Do not install the water heater where flammable products will be stored or used unless the main burner and igniter are at least 18" (457 cm) above the floor. This will reduce, but not eliminate the risk of vapors being ignited by the main burner or hot surface igniter.</p>	

When the water heater is installed directly on carpeting, the water heater shall be installed on a metal or wood panel extending beyond the full width and depth of the water heater by at least 3 in (76.2 mm) in any direction or, if the water heater is installed in an alcove or closet, the entire floor shall be covered by the panel. The panel must be strong enough to carry the weight of the heater when full of water.

⚠ WARNING	
Fire and Explosion Hazard	
	<p>Read the instruction manual before installing, using, or servicing the water heater.</p> <ul style="list-style-type: none"> • Improper use can result in fire or explosion. • Maintain required clearances to combustibles.

Minimum clearances between the water heater and combustible construction are 0 inch at the sides and rear, 5.5" (14.0 cm) from the front and 18" (45.7 cm) from the top. (Standard clearance.) If clearances stated on the heater differ from standard clearances, install water heater according to clearances stated on the heater.

Adequate clearance 30" (76 cm) for servicing this water heater should be considered before installation, such as changing the anode rods, control system components and gas control valve.

A minimum clearance of 5.5" (14.0 cm) must be allowed for access to replaceable and/or serviceable parts such as the thermostats, drain valve, condensate drain, temperature-pressure relief valve, clean out opening, and the vent connection (exhaust elbow).

When installing the heater, consideration must be given to proper location. Location selected should be as close to the wall as practicable and as centralized with the water piping system as possible.

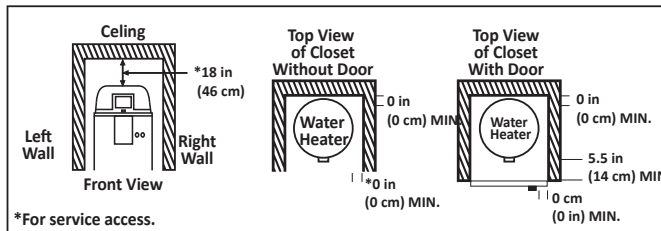
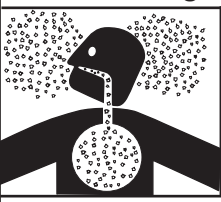

Figure 7. Enclosure Installation Clearances

INSULATION BLANKETS

⚠ WARNING	
Breathing Hazard - Carbon Monoxide Gas	
	<ul style="list-style-type: none"> • Do not obstruct water heater air intake with insulating blanket. • Gas and carbon monoxide detectors are available. • Install water heater in accordance with the instruction manual.
<p>Breathing carbon monoxide can cause brain damage or death. Always read and understand instruction manual.</p>	

Insulation blankets are available to the general public for external use on gas water heaters but are not necessary with these products. The purpose of an insulation blanket is to reduce the standby heat loss encountered with storage tank heaters. Your water heater meets or exceeds the Energy Policy Act standards with respect to insulation and standby loss requirements, making an insulation blanket unnecessary.

Should you choose to apply an insulation blanket to this heater, you should follow these instructions (For identification of components mentioned below. See **Figure 1** (page 10) and **Figure 2** (page 11). Failure to follow these instructions can restrict the air flow required for proper combustion, potentially resulting in fire, asphyxiation, serious personal injury or death.

- **Do not** apply insulation to the top of the water heater, as this will interfere with safe operation of the blower assembly.
- **Do not** cover the control system LCD on top of the water heater.
- **Do not** cover the outer door, thermostat or temperature & pressure relief valve.
- **Do not** cover the instruction manual. Keep it on the side of the water heater or nearby for future reference.
- **Do** obtain new warning and instruction labels from the manufacturer for placement on the blanket directly over the existing labels.
- **Do** inspect the insulation blanket frequently to make certain it does not sag, thereby obstructing combustion air flow.

COMBUSTION AIR AND VENTILATION

A gas water heater cannot operate properly without the correct amount of air for combustion. Do not install in a confined area such as a closet, unless you provide air as shown in *Locating The Water Heater* (page 15). Never obstruct the flow of ventilation air. If you have any doubts or questions at all, call your gas supplier. Failure to provide the proper amount of combustion air can result in a fire or explosion and cause death, serious bodily injury, or property damage.

 **WARNING**

Breathing Hazard - Carbon Monoxide Gas



- Install water heater in accordance with the Instruction Manual and **NFPA 54** or **CAN/CSA-B149.1**.
- To avoid injury, combustion and ventilation air must be taken from outdoors.
- Do not place chemical vapor emitting products near water heater.

Breathing carbon monoxide can cause brain damage or death. Always read and understand instruction manual.

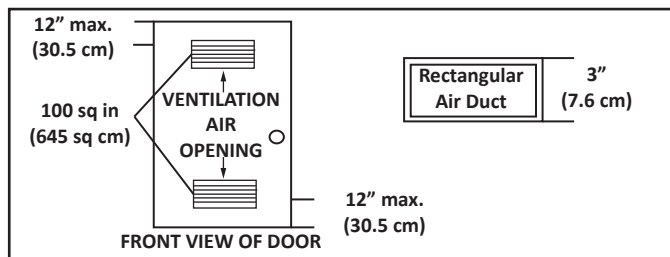

Figure 8. Enclosure Door Vent Clearances

If this water heater will be used in beauty shops, barber shops, cleaning establishments, or self-service laundries with dry cleaning equipment, it is imperative that the water heater(s) be installed direct vent so that all air for combustion and ventilation is taken from outdoors.

Propellants of aerosol sprays and volatile compounds, (cleaners, chlorine based chemicals, refrigerants, etc.) in addition to being highly flammable in many cases, will also react to form corrosive acids when exposed to the combustion products of the water heater. The results can be hazardous, and also cause product failure.

UNCONFINED SPACE

An Unconfined Space is one whose volume is not less than 50 cubic feet per 1,000 Btu/hr (4.8 cubic meters per kW) of the total input rating of all appliances installed in the space. Rooms communicating directly with the space, in which the appliances are installed, through openings not furnished with doors, are considered a part of the unconfined space.

Makeup air requirements for the operation of exhaust fans, kitchen ventilation systems, clothes dryers and fireplaces shall also be considered in determining the adequacy of a space to provide combustion, ventilation and dilution air.

UNUSUALLY TIGHT CONSTRUCTION

In unconfined spaces in buildings, infiltration may be adequate to provide air for combustion, ventilation and dilution of flue gases. However, in

buildings of unusually tight construction (for example, weather stripping, heavily insulated, caulked, vapor barrier, etc.) additional air must be provided using the methods described in the Confined Space section that follows.

CONFINED SPACE

A Confined Space is one whose volume is less than 50 cubic feet per 1,000 Btu/hr (4.8 cubic meters per kW) of the total input rating of all appliances installed in the space.

Openings must be installed to provide fresh air for combustion, ventilation and dilution in confined spaces. The required size for the openings is dependent on the method used to provide fresh air to the confined space and the total Btu/hr input rating of all appliances installed in the space.

DIRECT VENT APPLIANCES

Appliances installed in a Direct Vent configuration that derive all air for combustion from the outdoor atmosphere through sealed intake air piping are not factored in the total appliance input Btu/hr calculations used to determine the size of openings providing fresh air into confined spaces.

EXHAUST FANS

Where exhaust fans are installed, additional air shall be provided to replace the exhausted air. When an exhaust fan is installed in the same space with a water heater, sufficient openings to provide fresh air must be provided that accommodate the requirements for all appliances in the room and the exhaust fan. Undersized openings will cause air to be drawn into the room through the water heater's vent system causing poor combustion. Sooting, serious damage to the water heater and the risk of fire or explosion may result. It can also create a risk of asphyxiation.

LOUVERS AND GRILLES

The free areas of the fresh air openings in the instructions that follow do not take in to account the presence of louvers, grilles or screens in the openings.

The required size of openings for combustion, ventilation and dilution air shall be based on the net free area of each opening. Where the free area through a design of louver or grille or screen is known, it shall be used in calculating the size of opening required to provide the free area specified. Where the louver and grille design and free area are not known, it shall be assumed that wood louvers will have 25% free area and metal louvers and grilles will have 75% free area. Non motorized louvers and grilles shall be fixed in the open position.

FRESH AIR OPENINGS FOR CONFINED SPACES

The following instructions shall be used to calculate the size, number and placement of openings providing fresh air for combustion, ventilation and dilution in confined spaces. The illustrations shown in this section of the manual are a reference for the openings that provide fresh air into confined spaces only. **Do not** refer to these illustrations for the purpose of vent installation. See *Venting Installation* (page 27) for complete venting installation instructions.

Outdoor Air Through Two Openings

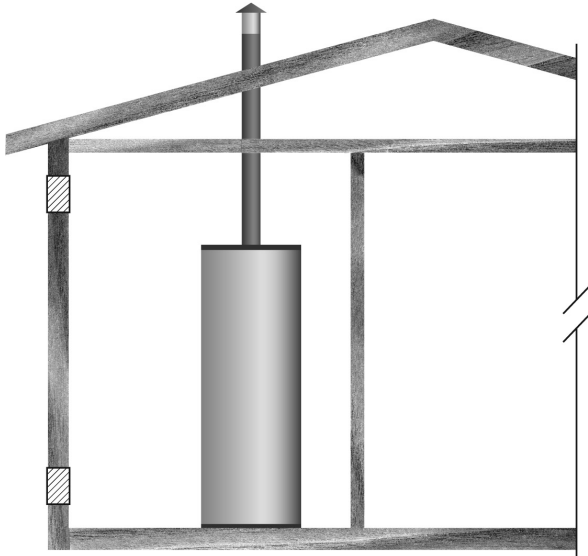

Figure 9. Outdoor Air Through Two Openings

The confined space shall be provided with two permanent openings, one commencing within 12 inches (300 mm) of the top and one commencing within 12 inches (300 mm) of the bottom of the enclosure. The openings shall communicate directly with the outdoors. See **Figure 9**.

Each opening shall have a minimum free area of 1 square inch per 4,000 Btu/hr (550 mm² per kW) of the aggregate input rating of all appliances installed in the enclosure. Each opening shall not be less than 100 square inches (645 cm²).

Outdoor Air Through One Opening

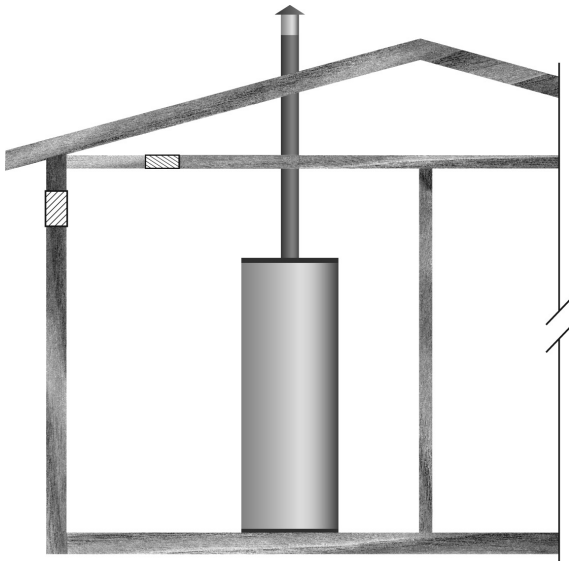

Figure 10. Outdoor Air Through One Opening

Alternatively a single permanent opening, commencing within 12 inches (300 mm) of the top of the enclosure, shall be provided. See **Figure 10**. The water heater shall have clearances of at least 1 inch (25 mm) from the sides and back and 6 inches (150 mm) from the front of the appliance. The opening shall directly communicate with the outdoors or shall communicate through a vertical or horizontal duct to the outdoors or spaces that freely communicate with the outdoors and shall have a minimum free area of the following:

1. 1 square inch per 3000 Btu/hr (733 mm² per kW) of the total input rating of all appliances located in the enclosure.
2. Not less than the sum of the areas of all vent connectors in the space.

Outdoor Air Through Two Horizontal Ducts

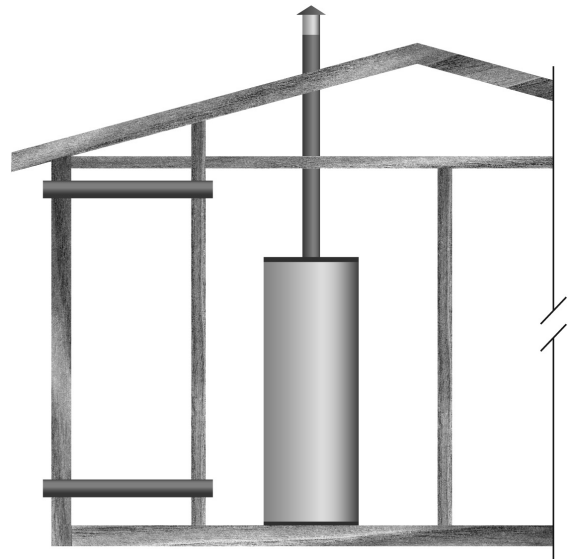

Figure 11. Outdoor Air Through Two Horizontal Ducts

The confined space shall be provided with two permanent horizontal ducts, one commencing within 12 inches (300 mm) of the top and one commencing within 12 inches (300 mm) of the bottom of the enclosure. The horizontal ducts shall communicate directly with the outdoors. See **Figure 11**.

Each duct opening shall have a minimum free area of 1 square inch per 2,000 Btu/hr (1100 mm² per kW) of the aggregate input rating of all appliances installed in the enclosure.

When ducts are used, they shall be of the same cross sectional area as the free area of the openings to which they connect. The minimum dimension of rectangular air ducts shall be not less than 3 inches.

Air From Other Indoor Spaces

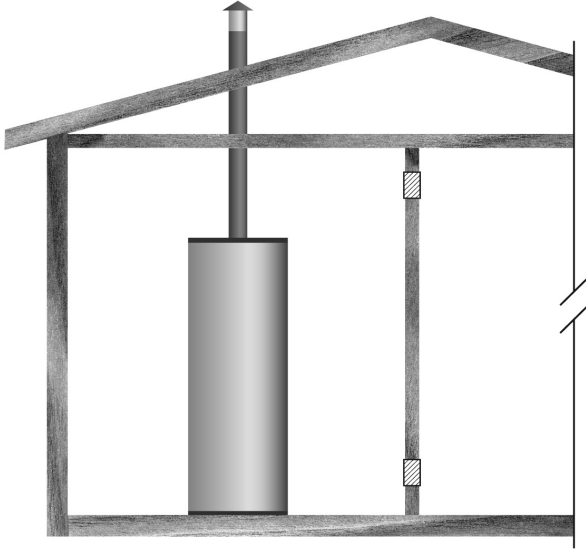

Figure 12. Air From Other Indoor Spaces

The confined space shall be provided with two permanent openings, one commencing within 12 inches (300 mm) of the top and one commencing within 12 inches (300 mm) of the bottom of the enclosure. See **Figure 12**.

Each opening shall communicate directly with an additional room(s) of sufficient volume so that the combined volume of all spaces meets the criteria for an Unconfined Space.

Each opening shall have a minimum free area of 1 square inch per 1,000 Btu/hr (2200 mm² per kW) of the aggregate input rating of all appliances installed in the enclosure. Each opening shall not be less than 100 square inches (645 cm²).

INSTALLATION REQUIREMENTS

CHEMICAL VAPOR CORROSION

Corrosion of the flue-ways and vent system may occur if air for combustion contains certain chemical vapors. Such corrosion may result in failure and risk of asphyxiation.

Spray can propellants, cleaning solvents, refrigerator and air conditioning refrigerants, swimming pool chemicals, calcium and sodium chloride (water softener salt), waxes, and process chemicals are typical compounds which are potentially corrosive.

Do not store products of this sort near the heater. Also, air which is brought in contact with the heater should not contain any of these chemicals. If necessary, uncontaminated air should be obtained from remote or outside sources. The limited warranty is voided when failure of water heater is due to a corrosive atmosphere. (See limited warranty for complete terms and conditions).

WATER PIPING

⚠ DANGER	
Burn Hazard	
	<p>Because of the increased risk from scalding, if you set the water heater's gas control knob higher than 120°F (49°C), install thermostatic point-of-use mixing valves at each point of use. Due to the increased risk of scalding, do not set the temperature of the thermostatic mixing valves above 120°F (49°C).</p>

Hotter Water Can Scald

Water heaters are intended to produce hot water. Water heated to a temperature which will satisfy space heating, clothes washing, dish washing, cleaning and other sanitizing needs can scald and permanently injure you upon contact. Some people are more likely to be permanently injured by hot water than others. These include the elderly, children, the physically or developmentally disabled. If anyone using hot water fits into one of these groups or if there is a local code or state law requiring a certain temperature water at the hot water tap, then you must take special precautions.

In addition to using the lowest possible temperature setting that satisfies the demand of the application a means, such as a thermostatic point-of-use mixing valve, for example, can be used at the hot water taps used by these people to reduce the water temperature.

Check State and/or local codes for thermostatic point-of-use mixing valve requirements and installation practices.

Consult a Qualified Installer or Service Agency. Follow manufacturer's instructions for installation of the valves. Before changing the factory setting on the thermostat, read the Temperature Regulation section in this manual.

⚠ WARNING

Toxic Chemical Hazard



Connecting the water heater to a non-potable water system might result in chemical or biological contamination of the water heater.

Do not connect the water heater to a non-potable water system.

This water heater shall not be connected to any heating systems or component(s) used with a non-potable water heating appliance.

All piping components connected to this unit for space heating applications shall be suitable for use with potable water.

Toxic chemicals, such as those used for boiler treatment shall not be introduced into this system.

When the system requires water for space heating at temperatures higher than required for domestic water purposes, a thermostatic point-of-use mixing valve must be installed.

These water heaters can be used for water heating applications alone or both water heating and space heating, but cannot be used for space heating applications alone.

POWER SUPPLY

The water heaters covered in this manual require a 120 VAC, 1Ø (single phase), 60 Hz, 15 amp power supply and must also be electrically grounded in accordance with local codes or, in the absence of local codes, with the **National Electrical Code, ANSI/NFPA 70** or the **Canadian Electrical Code, CSA C22.1**.

If any of the original wire as supplied with the water heater must be replaced, it must be replaced with 105°C rated wiring or its equivalent, except in the burner housing. In this case 200°C rated wire must be used.

DEDICATED POWER WIRING AND BREAKERS

Dedicated power supply wires, ground wiring and dedicated circuit breakers often prevent electrical line noise and should be considered when installing the water heater.

Note: This water heater should not be connected to an electrical supply with a Ground Fault Circuit Interrupter (GFCI) or Arc Fault Circuit Interrupter (AFCI) with Integral GFCI protection as defined in **NFPA 70, CSA C22.1 and UL 943**.

POWER FLUCTUATIONS AND ELECTRICAL NOISE

The water heater's control system requires a source of stable clean electricity for proper operation. Connecting the water heater to a branch circuit that is subject to fluctuations in voltage level or electrical line noise such as EMI (electromagnetic interference) or RFI (radio frequency interference) may cause erratic control system operation and malfunction.

A high quality power supply filter/suppressor must be installed if the above conditions exist.

Note: Malfunctions caused by the power supply and the costs to install power supply filters are not covered under the limited warranty.

THERMOSTATIC POINT-OF-USE MIXING VALVES

⚠ DANGER

Burn Hazard



Because of the increased risk from scalding, if you set the water heater's gas control knob higher than 120°F (49°C), install thermostatic point-of-use mixing valves at each point of use. Due to the increased risk of scalding, do not set the temperature of the thermostatic mixing valves above 120°F (49°C).

Water heated to a temperature which will satisfy clothes washing, dish washing, and other sanitizing needs can scald and cause permanent injury upon contact. Short repeated heating cycles caused by small hot water uses can cause temperatures at the point of use to exceed the water heater's temperature setting by up to 20°F (11°C).

Some people are more likely to be permanently injured by hot water than others. These include the elderly, children, the infirm and the physically/mentally disabled. **Table 4** shows the approximate time-to-burn relationship for normal adult skin. If anyone using hot water provided by the water heater being installed fits into one of these groups or if there is a local code or state law requiring a certain water temperature at the point of use, then special precautions must be taken.

In addition to using the lowest possible temperature setting that satisfies the demand of the application a means, such as a thermostatic point-of-use mixing valve, for example, can be used at the hot water taps used by these people to reduce the water temperature.

Check State and/or local codes for thermostatic point-of-use mixing valve requirements and installation practices.

Thermostatic point-of-use mixing valve are available at plumbing supply stores. Consult a Qualified Installer or Service Agency. Follow mixing valve manufacturer's instructions for installation of the valves.

In all cases, the following burn table must be used.

Water Temperature °F (°C)	Time for 1st Degree Burn (Less Severe Burns)	Time for Permanent Burns 2nd & 3rd Degree (Most Severe Burns)
110 (43)	(Normal shower temp.)	
116 (47)	(Pain threshold)	
116 (47)	35 minutes	45 minutes
122 (50)	1 minute	5 minutes
131 (55)	5 seconds	25 seconds
140 (60)	2 seconds	5 seconds
149 (65)	1 second	2 seconds
154 (68)	Instantaneous	1 second

(U.S. Government Memorandum, C.P.S.C., Peter L. Armstrong, Sept. 15, 1978)

GAS SUPPLY SYSTEMS

Low pressure building gas supply systems are defined as those systems that cannot under any circumstances exceed 14" W.C. (1/2 PSI Gauge). These

systems do not require pressure regulation. Measurements should be taken to insure that gas pressures are stable and fall within the requirements stated on the water heater rating plate. Readings should be taken with all gas burning equipment off (static pressure) and with all gas burning equipment running at maximum rate (dynamic pressure). The gas supply pressure must be stable within 1.5" W.C. from static to dynamic pressure to provide good performance. Pressure drops that exceed 1.5" W.C. may cause rough starting, noisy combustion or nuisance outages. Increases or spikes in static pressure during off cycles may cause failure to ignite or in severe cases damage to water heater gas control valves. If your low pressure system does NOT meet these requirements, the installer is responsible for the corrections.

High pressure building supply systems use pressures that exceed 14" W.C. (1/2 PSI Gauge). These systems must use field-supplied regulators to lower the gas pressure to less than 14" W.C. (1/2 PSI Gauge). Appliances require gas regulators that are properly sized for the water heater input and deliver the rating plate specified pressures. Gas supply systems where pressure exceeds 5 PSI often require multiple regulators to achieve desired pressures. Systems in excess of 5 PSI building pressure should be designed by gas delivery professionals for best performance. Water heaters connected to gas supply systems that exceed 14" W.C. (1/2 PSI Gauge) at any time must be equipped with a gas supply regulator.

GAS PRESSURE REQUIREMENTS

All models require a minimum gas supply pressure of 3.5" W.C.(0.87 kPa) for natural gas and 8.0" W.C. (1.99 kPa) for propane. The minimum supply pressure is measured while gas is not flowing (static pressure) AND while gas is flowing (dynamic pressure). The supply pressure (static and dynamic) should never fall below 3.5" W.C.(0.87 kPa) for natural gas or 8.0" W.C. (1.99 kPa) for propane. The supply pressure should be measured with all gas fired water heaters connected to the common main firing at full capacity. If the supply pressure drops more than 1.5" W.C. (0.37 kPa) as gas begins to flow to the water heater then the supply gas system including the gas line and/or the gas regulator may be restricted or undersized. See **Supply Gas Regulator** (page 21) and **Gas Piping** (page 37). The gas control valve on all models has a maximum gas supply pressure limit of 14" W.C.(3.48 kPa) The maximum supply pressure is measured while gas is not flowing (static pressure) AND while gas is flowing (dynamic pressure).

SUPPLY GAS REGULATOR

The maximum allowable gas supply pressure for this water heater is 14 inches W.C. (3.5 kPa). Install a positive lock-up gas pressure regulator in the gas supply line if inlet gas pressure can exceed 14 inches W.C. (3.5 kPa) at any time. Regulators must be sized/used according to manufacturer's specifications.

If a positive lock-up regulator is required follow these instructions:

1. Positive lock-up gas pressure regulators must be rated at or above the input Btu/hr rating of the water heater they supply.
2. Supply gas regulators shall have inlet and outlet connections not less than the minimum supply gas line size for the water heater they supply
3. Positive lock-up gas pressure regulator(s) should be installed no closer than 3 feet (1 meter) and no farther than 8 feet (2.4 meters) from the water heater's inlet gas connection.
4. After installing the positive lock-up gas pressure regulator(s) an initial nominal supply pressure setting of 7.0" W.C.(1.74 kPa) for Natural Gas and 11.0" W.C. (2.74 kPa) for Propane (LP) while the water heater is operating is recommended and will generally provide good water heater operation. Some additional adjustment may be required later to maintain a steady gas supply pressure.

- 5. When installing multiple water heaters in the same gas supply system it is recommended that individual positive lock-up gas pressure regulators be installed at each unit.

All gas piping must comply with local codes and ordinances or with the current editions *National Fuel Gas Code (ANSI Z223.1/NFPA-54)* or the *Natural Gas and Propane Installation Code (CAN/CSA B149.1)* whichever applies. Copper or brass tubing and fittings (except tin lined copper tubing) shall not be used.

If the gas control valve is subjected to pressures exceeding 14 in wc (3.5 kPa), the damage to the gas control valve could result in a fire or explosion from leaking gas.

If the main gas line Shut-off serving all gas water heaters is used, also turn off the gas at each water heater. Leave all gas appliances shut off until the water heater installation is complete.

A gas line of sufficient size must be run to the water heater. Consult the current edition of *National Fuel Gas Code (ANSI Z223.1/NFPA 54)* or the *Natural Gas and Propane Installation Code (CAN/CSA B149.1)* and your gas supplier concerning pipe size.

There must be:

- A readily accessible manual shut off valve in the gas supply line serving the water heater, and
- A sediment trap ahead of the gas control valve to help prevent dirt and foreign materials from entering the gas control valve.
- A ground joint union of proper size between the manual shut off valve and control valve to permit servicing of the unit.

Be sure to check all the gas piping for leaks before lighting the water heater. Use a soapy water solution, not a match or open flame. Rinse off soapy solution and wipe dry.

Ensure that the gas line is properly supported to reduce the weight on the gas train support.

SPACE HEATING AND POTABLE WATER SYSTEM

Your water heater is equipped with inlet/outlet connections for use in space heating applications. See **Figure 13**. If this water heater is to be used to supply both space heating and potable (drinking) water, the instructions listed below must be followed:

- Be sure to follow the manual(s) shipped with the air handler or other type heating system.
- This water heater cannot be used in space heating applications only.
- This water heater is not to be used as a replacement for an existing boiler installation.
- Do not use with piping that has been treated with chromates, boiler seal or other chemicals and do not add any chemicals to the water heater piping
- If the space heating system requires water temperatures in excess of 120°F, a thermostatic point-of-use mixing valve must be installed per the manufacturer’s instructions in the potable hot water supply to limit the risk of scald injury.

- Pumps, valves, piping and fittings must be compatible with potable water.
- A properly installed flow control valve is required to prevent thermosiphoning. Thermosiphoning is the result of a continuous flow of water through the air handler circuit during the off cycle. Weeping (blow off) of the temperature and pressure relief valve (T & P relief valve) or higher than normal water temperatures are the first signs of thermosiphoning.
- The hot water line from the water heater should be vertical past any mixing valve or supply line to the heating system to remove air bubbles from the system Do not connect the water heater to any system or components previously used with non-potable water heating appliances when used to supply potable water.

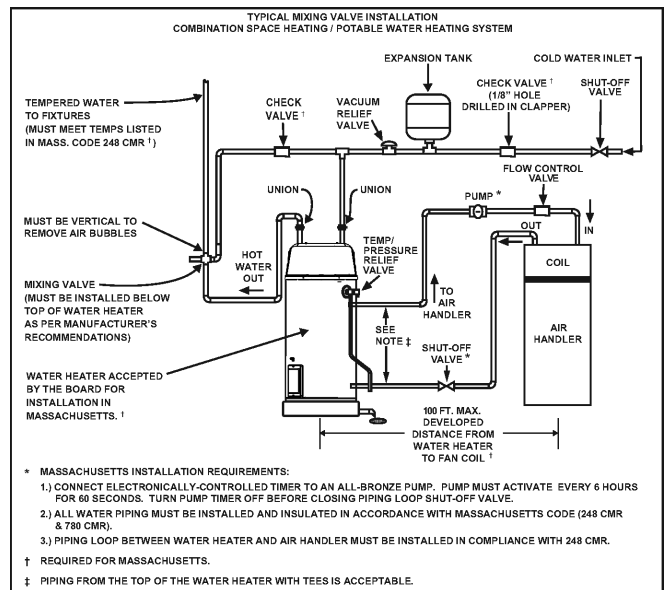

Figure 13. Typical Mixing Valve and Space Heating Installation

CLOSED WATER SYSTEMS

Water supply systems may, because of code requirements or such conditions as high line pressure, among others, have installed devices such as pressure reducing valves, check valves, and back flow preventers. Devices such as these cause the water system to be a closed system.

THERMAL EXPANSION

As water is heated, it expands (thermal expansion). In a closed system the volume of water will grow when it is heated. As the volume of water grows there will be a corresponding increase in water pressure due to thermal expansion. Thermal expansion can cause premature tank failure (leakage). This type of failure is not covered under the limited warranty. Thermal expansion can also cause intermittent temperature-pressure relief valve operation: water discharged from the valve due to excessive pressure build up. This condition is not covered under the limited warranty. The temperature-pressure relief valve is not intended for the constant relief of thermal expansion.

A properly sized thermal expansion tank should be installed on all closed systems to control the harmful effects of thermal expansion. Contact a local plumbing service agency to have a thermal expansion tank installed.

CAUTION	
Property Damage Hazard	
	<p>Avoid water heater damage from pressure fluctuations in closed water systems.</p> <ul style="list-style-type: none"> • Fill tank with water before operating. • Install thermal expansion tank if necessary. • Do not apply heat to cold water inlet. • Contact qualified installer or service agency.

Note: To protect against untimely corrosion of hot and cold water fittings, it is strongly recommended that dielectric unions or couplings be installed on this water heater when connected to copper pipe. See *Figure 14* also.

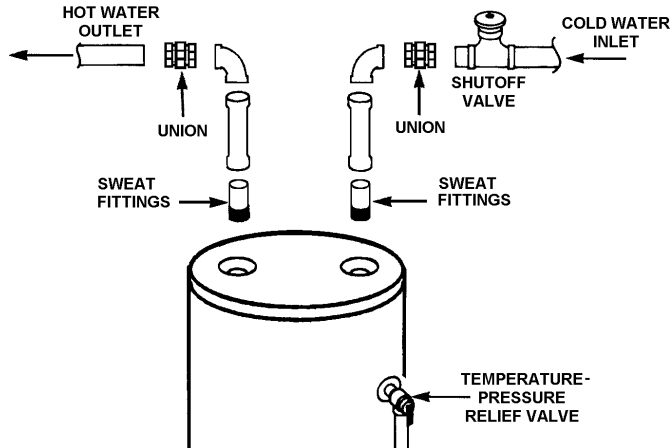

Figure 14. Typical Water Piping Configuration

Figure 14 shows the typical attachment of the water piping to the water heater. The water heater is equipped with 3/4 inch NPT water connections for 50 gallon nominal capacity unit and 1 inch NPT water connections for 75 gallon nominal capacity unit.

Note: If using copper tubing, solder tubing to an adapter before attaching the adapter to the water heater connections. Do not solder the water lines directly to the water heater connections. It will harm the dip tube and damage the tank, T & P Valve and Pipe Insulation (if supplied)

Fit pipe insulation over the incoming cold water line and the hot water line. Make sure that the insulation is against the top cover of the heater. Fit T & P valve insulation over valve. Make sure that the insulation does not interfere with the lever of the T & P valve.

Secure all insulation using tape.

TEMPERATURE-PRESSURE RELIEF VALVE

This water heater is provided with a properly rated/sized and certified combination Temperature-Pressure Relief Valve (T&P relief valve) by the manufacturer. The valve is certified by a nationally recognized testing laboratory that maintains periodic inspection of production of listed equipment of materials as meeting the requirements for *Relief Valves for Hot Water Supply Systems, ANSI Z21.22 • CSA 4.4*, and the code requirements of *ASME*.

If replaced, the new T&P valve must meet the requirements of local codes, but not less than a combination Temperature-Pressure Relief Valve rated/sized and certified as indicated in the above paragraph. The new valve must be marked with a maximum set pressure not to exceed the marked hydrostatic working pressure of the water heater (150 psi = 1,035 kPa) and

a discharge capacity not less than the water heater Btu/hr or kW input rate as shown on the water heater’s model rating plate.

Note: In addition to the factory-installed Temperature-Pressure Relief Valve on the water heater, each remote storage tank that may be installed and piped to a water heating appliance must also have its own properly sized, rated and approved Temperature-Pressure Relief Valve installed.

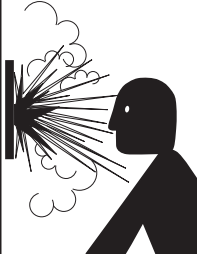
WARNING	
Explosion Hazard	
	<p>Normal operation of the water heater can cause it to become sufficiently over-heated and/or over-pressurized that it can explode, resulting in property damage, sever injury, or death.</p> <p>To avoid this hazard, you must install a properly-sized temperature-pressure relief valve in opening provided.</p> <ul style="list-style-type: none"> • The temperature-pressure relief valve must comply with <i>ANSI Z21.22-CSA 4.4</i> and <i>ASME</i> code. • Do not plug, block, or cap the discharge line.

For safe operation of the water heater, the Temperature-Pressure Relief Valve must not be removed from its designated opening nor plugged. The Temperature-Pressure Relief Valve must be installed directly into the fitting of the water heater designed for the relief valve. Install discharge piping so that any discharge will exit the pipe within 6 inches (15.2 cm) above an adequate floor drain, or external to the building. In cold climates it is recommended that it be terminated at an adequate drain inside the building. Be certain that no contact is made with any live electrical part. The discharge opening must not be blocked or reduced in size under any circumstances. Excessive length, over 30 feet (9.14 m), or use of more than four elbows can cause restriction and reduce the discharge capacity of the valve.

No valve or other obstruction is to be placed between the Temperature-Pressure Relief Valve and the tank. Do not connect discharge piping directly to the drain unless a 6” (15.2 cm) air gap is provided. To prevent bodily injury, hazard to life, or property damage, the temperature-pressure relief valve must be allowed to discharge water in adequate quantities should circumstances demand. If the discharge pipe is not connected to a drain or other suitable means, the water flow may cause property damage.

CAUTION	
Property Damage Hazard	
	<p>While the water heater is in routine operation, it can release hot water from the temperature-pressure relief valve discharge pipe in quantities that could cause damage to the surroundings.</p> <p>Locate the water heater near an adequate drain and in an area where water from the temperature-pressure relief valve discharge pipe will not result in damage to the area or the lower floors of the structure.</p>

T&P VALVE DISCHARGE PIPE REQUIREMENTS:

- Shall not be smaller in size than the outlet pipe size of the valve, or have any reducing couplings or other restrictions.
- Shall not be plugged or blocked.

- Shall not be exposed to freezing temperatures.
- Shall be of material listed for hot water distribution.
- Shall be installed so as to allow complete drainage of both the Temperature-Pressure Relief Valve and the discharge pipe.
- Must terminate a maximum of six inches (15.2 cm) above a floor drain or external to the building. In cold climates, it is recommended that the discharge pipe be terminated at an adequate drain inside the building.
- Shall not have any valve or other obstruction between the temperature-pressure relief valve and the drain.

⚠ DANGER	
Burn Hazard	
	<p>The discharge water from the temperature-pressure relief valve is hot enough to cause burns.</p> <p>Keep clear of the temperature-pressure relief valve discharge outlet.</p>

The Temperature-Pressure Relief Valve must be manually operated at least twice a year. Caution should be taken to ensure that (1) no one is in front of or around the outlet of the Temperature-Pressure Relief Valve discharge line, and (2) the water manually discharged will not cause any bodily injury or property damage because the water may be extremely hot. If after manually operating the valve, it fails to completely reset and continues to release water, immediately close the cold water inlet to the water heater, follow the draining instructions in this manual, and replace the Temperature-Pressure Relief Valve with a properly rated/sized new one.

Note: The purpose of a Temperature-Pressure Relief Valve is to prevent excessive temperatures and pressures in the storage tank. The T&P valve is not intended for the constant relief of thermal expansion. A properly sized thermal expansion tank must be installed on all closed systems to control thermal expansion. See **Closed Water Systems** (page 22) and **Thermal Expansion** (page 22).

If you do not understand these instructions or have any questions regarding the Temperature-Pressure Relief Valve call the toll free number found on the warranty sheet provided with the water heater for technical assistance.

CONDENSATE PIPING

The water heaters covered in this manual are condensing appliances and require a building drain to be located in close proximity to allow the condensate to drain safely.

Condensate drains from the water heater at the exhaust elbow located at the bottom. The field-installed condensate drain line must not be elevated above the condensate drain connection on the condensate trap. See **Figure 15**. If the condensate does not drain properly it will build up in the exhaust (vent) elbow. This will restrict the flow of flue gases and cause the Blocked Exhaust pressure switch to open its contacts. The control system monitors all pressure switches, if the Blocked Exhaust Switch contacts are open the control system will lock out and disable heating operation. The “Blocked Exhaust” Fault message will be displayed on the control system’s LCD.

The Condensate Clean-out Cap must be on and tight when unit is in operation.

Note: If the “Blocked Exhaust” Fault message is ever displayed on the control system LCD, check the condensate drain first and ensure it is not blocked.

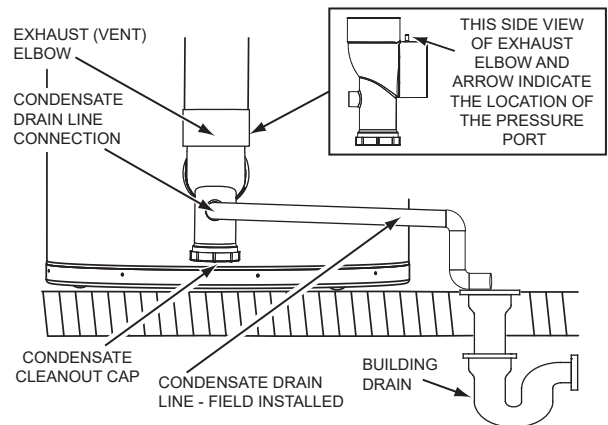

Figure 15. Condensate Drain Configuration

DO NOT remove the factory-installed exhaust/condensate elbow for any reason. See **Figure 15**. The water heater’s vent pipe is under a slight positive pressure while unit is in operation. The water trap inside of the exhaust/condensate elbow prevents flue gases from escaping into the installed space.

Do not install any external condensate trap. The exhaust elbow assembly has an internal condensate trap.

CONDENSATE PH LEVEL

The condensate drains from the water heater’s covered in this manual have pH levels between 4.3 and 5.0. Install a commercially available neutralizing kit if required by local codes.

Note: Lower pH levels are acidic. Do not connect a metal drain line, such as copper, to the water heater for this reason. See **Condensate Drain Installation** (page 36) .

HIGH ALTITUDE INSTALLATIONS

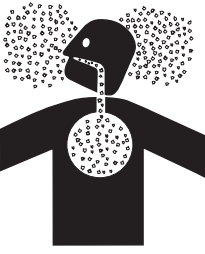
 WARNING	
Breathing Hazard - Carbon Monoxide Gas	
	<ul style="list-style-type: none">• Special considerations must be taken with installations above 10,100 (3,078 meters).• Please contact an A. O. Smith qualified service agent to obtain the proper setup and instructions before lighting.• Failure to implement the proper setup will result in improper and inefficient operation of the appliance, resulting in production of increased levels of carbon monoxide gas in excess of the safe limits which could result in serious personal injury or death.
Breathing carbon monoxide can cause brain damage or death. Always read and understand instruction manual.	

This high efficiency water heater is certified for use without modification for an altitude of 10,100 feet (3,078 m). Consult the factory for installation at altitudes over 10,100 feet (3,078 m).

Some gas utility companies derate their gas for altitude. Call the local gas or utility company to verify the BTU content.

Due to the input rate reduction at high altitudes, the output rating of the water heater is also reduced and should be compensated for in the sizing of the equipment for applications.

MASSACHUSETTS INSTALLATION REQUIREMENTS

For all side wall terminated, horizontally vented power vent, direct vent, and power direct vent gas fueled water heaters installed in every dwelling, building or structure used in whole or in part for residential purposes, including those owned or operated by the Commonwealth and where the side wall exhaust vent termination is less than seven (7) feet above finished grade in the area of the venting, including but not limited to decks and porches, the following requirements should be satisfied:

INSTALLATION OF CARBON MONOXIDE DETECTORS At the time of installation of the side wall horizontal vented gas fueled equipment, the installing plumber or gas-fitter should observe that a hard wired carbon monoxide detector with an alarm and battery back-up is installed on the floor level where the gas equipment is to be installed. In addition, the installing plumber or gas-fitter should observe that a battery operated or hard wired carbon monoxide detector with an alarm is installed on each additional level of the dwelling, building or structure served by the sidewall horizontal vented gas fueled equipment. It should be the responsibility of the property owner to secure the services of qualified licensed professionals for the installation of hard wired carbon monoxide detectors.

In the event that the side wall horizontally vented gas fueled equipment is installed in a crawl space or an attic, the hard wired carbon monoxide detector with alarm and battery back-up may be installed on the next adjacent floor level.

In the event that the requirements of this subdivision can not be met at the time of completion of installation, the owner should have a period of thirty (30) days to comply with the above requirements provided that during said thirty (30) day period, a battery operated carbon monoxide detector with an alarm should be installed.

APPROVED CARBON MONOXIDE DETECTORS Each carbon monoxide detector as required in accordance with the above provisions should comply with *NFPA 720* and be *ANSI/UL 2034* listed and *CSA* certified.

SIGNAGE A metal or plastic identification plate should be permanently mounted to the exterior of the building at a minimum height of eight (8) feet above grade directly in line with the exhaust vent terminal for the horizontally vented gas fueled heating appliance or equipment. The sign should read, in print size no less than one-half (1/2) inch in size, ***GAS VENT DIRECTLY BELOW. KEEP CLEAR OF ALL OBSTRUCTIONS.***

INSPECTION The state or local gas inspector of the side wall horizontally vented gas fueled equipment should not approve the installation unless,

upon inspection, the inspector observes carbon monoxide detectors and signage installed in accordance with the provisions of 248 CMR 5.08(2) (a) 1 through 4.

EXEMPTIONS: The following equipment is exempt from 248 CMR 5.08(2) (a)1 through 4:

1. The equipment listed in Chapter 10 entitled Equipment Not Required To Be Vented in the most current edition of NFPA 54 as adopted by the Board; and
2. Product Approved side wall horizontally vented gas fueled equipment installed in a room or structure separate from the dwelling, building, or structure used in whole or in part for residential purposes.

MANUFACTURER REQUIREMENTS - GAS EQUIPMENT VENTING SYSTEM PROVIDED When the manufacturer of Product Approved side wall horizontally vented gas equipment provides a venting system design or venting system components with the equipment, the instructions provided by the manufacturer for installation of the equipment and the venting system should include:

1. Detailed instructions for the installation of the venting system design or the venting system components; and
2. A complete parts list for the venting system design or venting system.

MANUFACTURER REQUIREMENTS - GAS EQUIPMENT VENTING SYSTEM NOT PROVIDED When the manufacturer of a Product Approved side wall horizontally vented gas fueled equipment does not provide the parts for venting the flue gases, but identifies special venting systems, the following requirements should be satisfied by the manufacturer:

1. The referenced special venting system instructions should be included with the appliance or equipment installation instructions; and
2. The special venting systems should be Product Approved by the Board, and the instructions for that system should include a parts list and detailed installation instructions.

A copy of all installation instructions for all Product Approved side wall horizontally vented gas fueled equipment, all venting instructions, all parts lists for venting instructions, and/or all venting design instructions should remain with the appliance or equipment at the completion of the installation.

VENTING INSTALLATION

⚠ WARNING

Breathing Hazard - Carbon Monoxide Gas



- Install vent system in accordance with codes.
- Do not operate water heater if any part has been exposed to flooding or water damage.
- High altitude models should be installed at elevations above 5,300 feet (1,615 m). For operation above 10,100 feet (3,079 m), a high altitude orifice must be installed.
- Do not operate if soot buildup is present.
- Do not obstruct water heater air intake with insulating jacket.
- Do not place chemical vapor emitting products near water heater.
- Gas and carbon monoxide detectors are available.
- No vent damper installation is compatible with this power vented water heater.
- Do NOT elevate any portion of the field supplied drain line beyond the 1/2" adapter above the adapter. This must be true for the entire length of the drain line including the exit into an appropriate drain.
- Condensate lines must be free and clear of debris and must not allow back flow through the hose. The condensate lines must be able to flow freely to an appropriate drain.
- Do not allow condensate lines to become crimped closed.
- Analyze the entire vent system to make sure that condensate will not become trapped in a section of vent pipe and therefore reduce the open cross sectional area of the vent.

Breathing carbon monoxide can cause brain damage or death. Always read and understand instruction manual.

building. Special consideration is recommended, before locating the vent termination near walkways, windows and building entrances.

Direct venting into dead spaces such as alleys, atriums, and inside corners can cause recirculation of flue gases. Recirculation of flue gases will cause sooting, and icing of the combustion air intake during severe cold weather. To prevent the recirculation of flue gases, maintain as much distance as possible between the combustion air intake and the exhaust vent terminal. See *Figure 23* (page 32) and *Figure 24* (page 33).

VENT/INTAKE MATERIAL

Approved vent and intake air pipe materials that may be used in the United States:

PVC pipe materials:

- DWV ASTM-D2665 or CSA B181.2
- Schedule 40, 80, 120 ASTM-D1785 or CSA B137.3
- SDR Series ASTM-2241 or CSA B137.3

CPVC pipe materials:

- CPVC 41 ASTM-D2846 or CSA B137.6
- Schedule 40, 80 ASTM-F441 or CSA B137.6
- SDR Series ASTM-F442

Polypropylene - See *Polypropylene Installations* (page 28).

- M & G Duravent PolyPro vent system
- Centrotherm InnoFlue vent system

Approved vent pipe materials that must be used in Canada:

- ULC S636 PVC / CPVC
- ULC S636 Polypropylene - See *Polypropylene Installations* (page 28).

Approved intake air pipe materials that must be used in Canada:

PVC pipe materials:

- DWV ASTM-D2665 or CSA B181.2
- Schedule 40, 80, 120 ASTM-D1785 or CSA B137.3
- SDR Series ASTM-D2241 or CSA B137.3

CPVC pipe materials:

- CPVC 41 ASTM-D2846 or CSA B137.6
- Schedule 40, 80 ASTM-F441 or CSA B137.6
- SDR Series ASTM-F442

Polypropylene - See *Polypropylene Installations* (page 28).

- M & G Duravent PolyPro vent system
- Centrotherm InnoFlue vent system

Where applicable, the installation of the venting system should be done in accordance with the venting system manufacturer's instructions.

Note: The use of cellular core PVC (ASTM F891), cellular core CPVC, or Radel® (polyphenolsulfone) in non-metallic venting systems is prohibited. Covering non-metallic vent pipe and fittings with thermal insulation is prohibited.

If the water heater is being installed as a replacement for an existing power vented heater in pre-existing venting, a thorough inspection of existing venting system must be performed prior to any installation work. Verify that correct material as detailed above has been used, and that the minimum or maximum vent lengths and terminal location as detailed in this manual have been met. Carefully inspect the entire venting system

VENT INSTALLATION CONSIDERATIONS

This water heater can be vented using room air for intake combustion air, or direct vented so that all intake air for combustion comes from the outside through a sealed pipe.

The water heater venting may be installed in four separate orientations depending on the requirements of the building and the water heater. The installer must decide which method is most appropriate for each installation. These orientations are:

1. Vertical Termination - vertical vent termination through unenclosed or enclosed areas with roof penetration. See *Vertical Vent Terminal Installation* (page 30).
2. Through-the-Wall Termination - horizontal vent termination directly through an outside wall. See *Figure 16* (page 29).
3. Horizontal Direct Vent - using Through-the-Wall Termination to exhaust flue products and piping to bring combustion air to the water heater from the outside. See *Figure 17* (page 29), *Figure 27* (page 34) and *Figure 28* (page 34).
4. Vertical Direct Vent - using a vertical vent termination to exhaust flue products and piping to bring combustion air to the water heater from outside. See *Figure 25* (page 34) and *Figure 26* (page 34).

In cold climates any water vapor remaining in the flue gases will condense into a cloud of vapor at the point where the vent system exits the

for any signs of cracks or fractures, particularly at joints between elbows and other fittings and straight runs of vent pipe. Check system for signs of sagging or other stresses in joints as a result of misalignment of any components in the system. If any of these conditions are found, they must be corrected in accordance with the venting instructions in this manual before completing installation and putting the water heater into service.

Note: For water heaters in locations with high ambient temperatures above 100°F (38°C) it is recommended that CPVC or Polypropylene pipe and fittings be used.

All vent (exhaust) pipes must be pitched a minimum of a 1/4" per foot back to the water heater to allow drainage of condensation.

POLYPROPYLENE INSTALLATIONS

The water heater has been approved to be installed with Polypropylene vent material as shown in **Table 5** and **Table 6**. The approved application of single wall, non-flexible, non-concentric Polypropylene vent material is offered by two specific manufacturers (Centrotherm ECO Systems and DuraVent Polypropylene). These listed products must be installed by following the vent manufacturer’s instructions. See **Table 7** on (page 29) to determine the maximum pipe length and number of elbows that can be used.

Insulation should not be used on Polypropylene venting materials. The use of insulation will cause increased vent wall temperatures, which could result in vent pipe failure.

Use only the adapters and vent system listed in tables below. DO **NOT** mix vent systems of different types or manufacturers. Failure to comply could result in severe personal injury, death, or substantial property damage.

Installations must comply with applicable national, state, and local codes. For Canadian installation, Polypropylene vent must be listed as a **ULC-S636** approved system. If Polypropylene vent is not required by your local code, you may use either PVC or CPVC pipes for your water heater that allows non-metallic venting material installations.

Polypropylene vent systems do not use cement to connect the pipe and elbow sections but use a push together gasket seal method. Do not attempt to connect Polypropylene with sealant cement. All vent connections **MUST** be secured by the vent manufacturer’s joint connector. The installer must use a specific vent starter adapter at the flue connection. The adapter is supplied by the vent manufacturer to adapt to its vent system.

In order to be in full compliance with **UL 1738** or **ULC-S636** and to meet the requirements of the water heater manufacturer, you must use the metal joint connector rings, available from the Polypropylene vent manufacturer, to stiffen the joints of 2", and 3" diameter pipes.

Nominal Pipe Diameter	Flue Outlet Adapter	Adapter Connector	Ring Connector	90 Degree Elbow	Vent Material	Terminal(s)
2"	2PPS-AD	PPS-PAC	2PPS-LB	2PPS-E90	2PPS	2PPS & 2PPS-BG for Exhaust; 2PPS-E90 & 2PPS-BG for Intake (Direct Vent only)
3"	3PPS-AD	PPS-PAC	3PPS-LB	3PPS-E90	3PPS	3PPS & 3PPS-BG for Exhaust; 3PPS-E90 & 3PPS-BG for Intake (Direct Vent only)

Never operate the water heater unless it is vented to the outdoors.

The instructions in this section of the manual must be followed to avoid choked combustion or recirculation of flue gases. Such conditions cause sooting of the combustion chamber, burners and flue, and creates a risk of asphyxiation.

For direct vent application where combustion air might be supplied from cold outdoor ambient temperatures through the fresh air intake piping system, it is recommended that a back-flow preventer and / or a drain tee be installed in the air intake before proceeding with installation of the rest of the fresh air intake piping. See **Direct Vent Air Intake Moisture Protection** (page 30) or call the toll free number found on the warranty sheet provided with the water heater for technical assistance.

Nominal Pipe Dia.	Flue Outlet Adapter	Adapter Connector	Ring Connector	90 Degree Elbow	Vent Material	Terminal(s)
2"	ISAGL 0202	IAFC02	IANS02	IS-ELL0287	ISVL02	ISVL02 & IASPP02 for Exhaust; ISELL0287 & IASPP02 for Intake (Direct Vent only)
3"	ISAGL 0303	IAFC03	IANS03	IS-ELL0387	ISVL03	ISVL03 & IASPP03 for Exhaust; ISELL0387 & IASPP03 for Intake (Direct Vent only)

VENT PIPE TERMINATION

The first step is to determine where the vent pipe will terminate. The vent may terminate through a sidewall as shown in **Figure 16** (page 29), **Figure 18** (page 30), and **Figure 19** (page 30) or through the roof as shown in **Figure 20** (page 31), **Figure 21** (page 31) and **Figure 22** (page 31).

The vent system must terminate so that proper clearances are maintained as cited in local codes or the current edition of the **National Fuel Gas Code, (ANSI Z223.1, 12.9.1 through 12.9.4)** or the **Natural Gas and Propane Installation Code (CAN/CSA-B149.1)**. See **Figure 23** (page 32) and **Figure 24** (page 33).

Plan the vent system layout so that proper clearances are maintained from plumbing and wiring.

Vent pipes serving power vented water heaters are classified by building codes as vent connectors. Required clearances from combustible materials must be provided in accordance with information in this manual under **Venting Installation** (page 27) and **Installation Requirements** (page 20), and with the **National Fuel Gas Code** and local codes.

PLANNING THE VENT SYSTEM

Plan the route of the vent system from the exhaust elbow to the planned location of the vent terminal.

Do not locate the vent termination over public walkways or a public area where condensate or vapor can cause a nuisance or ice hazard.

Water heaters covered by these instructions are Category IV appliances.

1. Layout total vent system to use a minimum of vent pipe and elbows.
2. This water heater is capable of venting flue gases in equivalent length of pipe as listed in **Table 7**.

Number of 90° Elbows	2" Maximum Pipe - ft.. (m)	3" Maximum Pipe - ft.. (m)
1	60 (18.2)	130 (39.6)
2	55 (16.8)	125 (38.1)
3	50 (15.2)	120 (36.6)
4	45 (13.7)	115 (35.0)
5	40 (12.1)	110 (33.5)
6	35 (10.7)	105 (32.0)

The minimum vent length for each of the pipe size is one 90° elbow plus 2' and 7' (0.61 m and 2.1 m) of straight pipe for air intake and exhaust vent respectively and the appropriate termination.

Note: The equivalent length of pipe listed above are exclusive of the termination. That is, the termination, with an installed screen, is assumed to be in the system and the remainder of the system must not exceed the lengths and number of elbows shown in **Table 7** (page 29).

If using 2" inch vent pipe: A 2" diameter vent pipe must be inserted and fastened to the exhaust elbow assembly.

If using 3" inch vent pipe: Two inches (5.1 cm) of 2" diameter pipe must be inserted and fastened to the exhaust elbow assembly before adding a 2' x 3" reducer to acquire the desired pipe diameter. A 3" coupling (supplied locally-a schedule 40 DWV) vent terminal must be obtained. A 3" diameter screen is supplied in the vent kit.

INSTALLATION OF HORIZONTAL THROUGH THE WALL VENT SYSTEM

If you are installing your system so that it vents through roof, please see **Vertical Vent Terminal Installation** (page 30).

VENT TERMINAL INSTALLATION, SIDEWALL

1. Install the vent terminal by using the cover plate as a template to mark the hole for the vent pipe to pass through the wall. **BEWARE OF CONCEALED WIRING AND PIPING INSIDE THE WALL.**
2. If the Vent Terminal is being installed on the outside of a finished wall, it may be easier to mark both the inside and outside wall. Align the holes by drilling a hole through the center of the template from the inside through to the outside. The template can now be positioned on the outside wall using the drilled hole as a centering point for the template.

A. MASONRY SIDE WALLS

Chisel an opening approximately one half inch (1.3 cm) larger than the marked circle.

B. WOODEN SIDE WALLS

Drill a pilot hole approximately one quarter inch (0.64 cm) outside of the marked circle. This pilot hole is used as a starting point for a saws-all or sabre saw blade. Cut around the marked circle staying approximately one quarter inch (0.64 cm) outside of the line. (This will allow the vent to easily slide through the opening. The resulting gap will be covered up by the Vent Terminal wall plate.) Repeat this step on inside wall if necessary.

Cut a length of pipe about 3.5 inches (8.9 cm) longer than the wall thickness at the opening. Glue the vent terminal to this section of pipe. Slide the wall plate over the pipe to stop against the vent terminal. Place a bead of caulking (not supplied) around the gap between the pipe and cover plate. Apply enough to fill some of the gap between the pipe and wall. Place some of the caulking on the back of the plate to hold it against the wall after installation. If the vent pipe is installed up to the wall, with a coupling on the end against the wall opening, the pipe with the vent terminal can be prepared for gluing before inserting through the wall. Slide the pipe through the wall and insert into the coupling on the other side of the wall, making sure that the vent terminal ends up pointed in the correct position. See **Figure 16**.

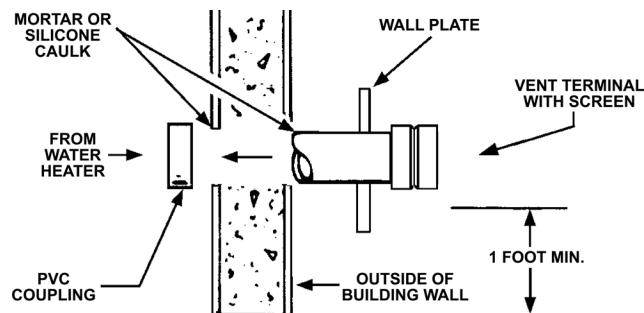

Figure 16. Sidewall Vent Termination

DIRECT VENT TERMINAL INSTALLATION

The air intake provided on the unit contains an air intake screen to prevent large particles from entering the unit.

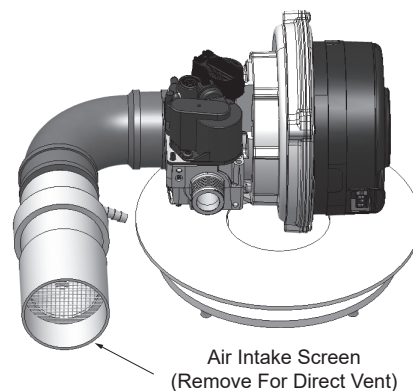

Figure 17. Blower Air Inlet Assembly

Note: When the unit is to be set up as a direct vent, the air intake screen must be removed. The air intake pipe may then be glued to the air intake provided on the unit. See **Figure 17** (page 29).

This unit consists of two terminals - an air intake terminal and an exhaust vent terminal. The air intake terminal is a 2" 90° PVC elbow with an air intake screen and the exhaust vent terminal is a 2" straight PVC coupling with a mesh wire screen.

Note: To prevent exhausting products from circulating to the air intake in windy/cold areas, the maximum practical distance between these two terminals is recommended.

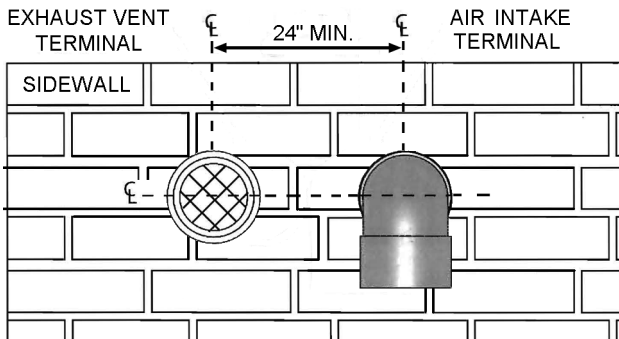

Figure 18. Sidewall Intake/Exhaust Separation Clearance

DIRECT VENT AIR INTAKE MOISTURE PROTECTION

The air intake piping in a direct vent system will normally not have any moisture accumulation in it. However, in certain cases, moisture may build up and needs to be drained. Typical situations include, but are not limited to:

- Cold outdoor temperature, particularly if the air inlet is short,
- Heater being used mostly for space heating and
- Air inlet pipe has vertical rise near the heater.

Installations with any of these conditions are required to provide a moisture drain with a trap that flows to a waste drain. See *Figure 25* (page 34), *Figure 26* (page 34), *Figure 27* (page 34) and *Figure 28* (page 34). A horizontal section of the air inlet pipe, near the heater should include a 2" by 2" by 1/2" tee and a hose barb fitting to drain the water. The tee should be as close to the heater as is practical. The drain tubing in any installation should have a loop trap and flow to an appropriate waste drain. The air intake drain line must be entirely separate from the exhaust vent outlet condensate line.

INSTALLATION SEQUENCE

1. After the points of termination have been determined, use the cover plates as templates to mark the holes for the vent pipes to be inserted through the wall. **BEWARE OF CONCEALED WIRING AND PIPING INSIDE OF WALL.** If the vent terminals are being installed on the outside of a finished wall, it may be easier to mark both the inside and outside wall. Align the holes by drilling a hole through the center of the template from the inside through to the outside. The template can now be positioned on the outside wall using the drilled holes as a centering point for the template.
 - A. **MASONRY SIDE WALLS** Chisel an opening approximately 1/2" (1.3 cm) larger than the marked circle.
 - B. **WOODEN SIDE WALLS** Drill a pilot hole approximately one quarter inch outside of the marked circle. This pilot hole is used as a starting point for a saws-all or sabre saw blade. Cut around the marked circle staying approximately one quarter inch outside of the line. (This will allow the vent pipe to easily slide through the opening. The resulting gap will be covered by the vent terminal cover plates.) Repeat this step on the inside wall if necessary.

2. Cut a length of pipe about 3.5" (8.9 cm) longer than the wall thickness at the opening.
3. Glue the air intake terminal to the section of the pipe.
4. Slide the wall plate over pipe to stop against air intake terminal.
5. Place a bead of caulking (not supplied) around the gap between the pipe and the wall. Place some of the caulking on the back of the plate to hold it against the wall after installation.
6. If the air intake pipe is installed up to the wall, with a coupling on the end against the wall opening, the pipe with the air intake terminal can be prepared for gluing before inserting through the wall. Slide the pipe through the wall and insert into coupling on the other side of the wall, making sure that the air intake terminal ends up pointed in the correct position (*Figure 18* and *Figure 19*).

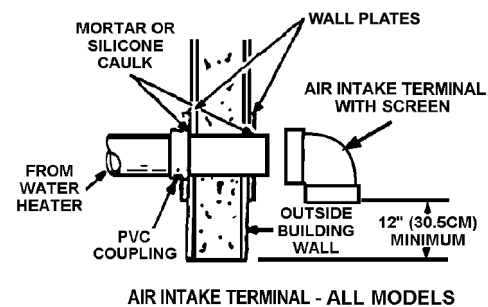
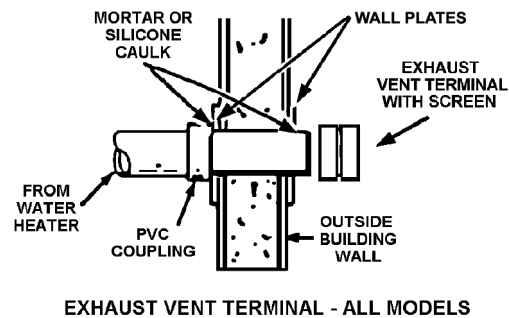

Figure 19. Side-Wall Intake/Exhaust Termination Installation

VERTICAL VENT TERMINAL INSTALLATION

WHEN TERMINATING THROUGH A ROOF, THE FOLLOWING SPECIFICATIONS PERTAINING TO TERMINAL LOCATION MUST BE FOLLOWED.

1. Proper support must be provided for all pipe protruding through the roof.
2. The vertical roof terminations should be sealed with a plumbing roof boot or equivalent flashing.
3. The air intake termination and the exhaust vent termination must penetrate the same side of roof.
4. The center line of the air intake termination and the center line of the exhaust vent termination must be no closer than 24" (61 cm). See *Figure 20* (page 31) and *Figure 21* (page 31).

FLAT ROOF INSTALLATION

On flat roof installations the air intake and the exhaust vent terminations must be a minimum of 24 inches (60 cm) above any parapet, vertical wall or structure within 10 feet (3 m) horizontally. See *Figure 22*.

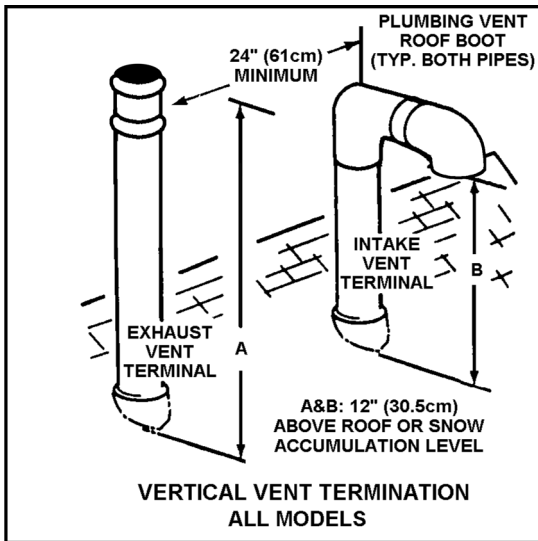

Figure 20. Pitched Roof Separation Clearances

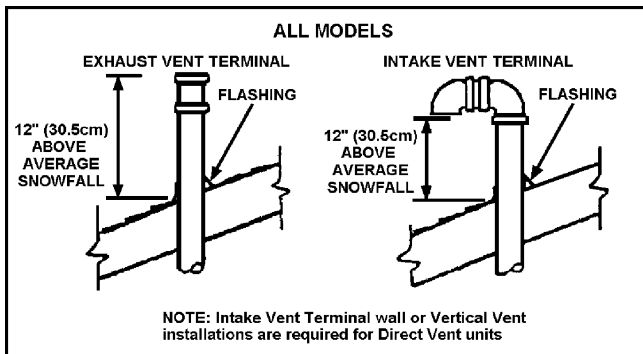

Figure 21. Pitched Roof Snow Clearances

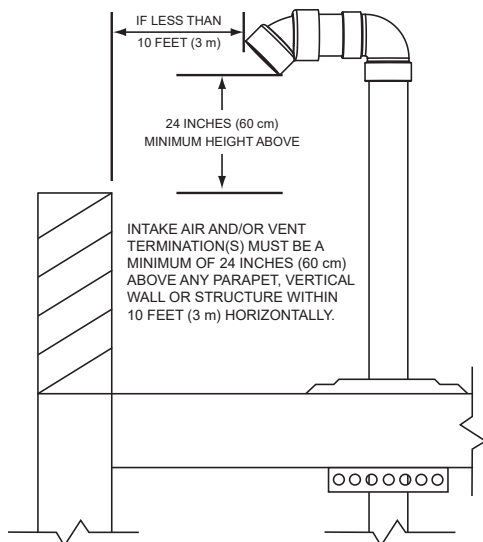

Figure 22. Flat Roof Clearances

SIDEWALL TERMINATION DIRECT VENT CLEARANCES

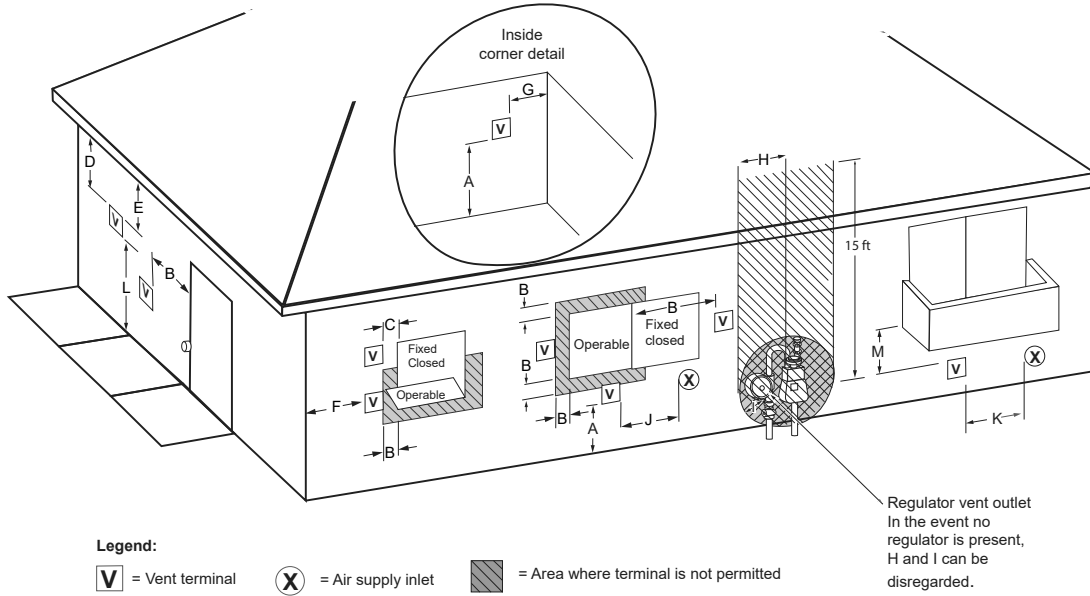

Figure 23. Direct Vent Using Outside Air

Vent terminal clearances for “Power Vent” installations. Power Vent configurations use room air for combustion.

Termination Clearances for Sidewall Direct Vent			
	Type of Clearance	Canadian Installations ¹	US Installations ²
A	Clearance above grade, veranda, porch, deck or balcony	12 inches (30 cm)	12 inches (30 cm)
B	Clearance to window or door that may be opened	<ul style="list-style-type: none"> 6 in (15 cm) for appliances ≤ 10,000 Btuh (3 kW) 12 in (30 cm) for appliances > 10,000 Btuh (3 kW) and ≤ 100,000 Btuh (30 kW), 36 in (91 cm) for appliances > 100,000 Btuh (30 kW) 	<ul style="list-style-type: none"> 4 feet (1.2 m) below or to side of opening; 1 foot (30 cm) above opening
C	Clearance to permanently closed window	6 inches (15 cm)*	6 inches (15 cm)*
D	Vertical clearance to ventilated soffit located above the terminal within a horizontal distance of 2 feet (61 cm) from the center line of the terminal	12 inches (30 cm)	12 inches (30 cm)
E	Clearance to unventilated soffit	12 inches (30 cm)	12 inches (30 cm)
F	Clearance to outside corner	2 feet (60 cm)*	2 feet (60 cm)*
G	Clearance to inside corner	18 inches (45 cm)*	18 inches (45 cm)*

Termination Clearances for Sidewall Direct Vent			
	Type of Clearance	Canadian Installations ¹	US Installations ²
H	Clearance to each side of center line extended above meter/regulator assembly	3 ft. (91 cm) within a height 15 ft. (4.6 m)	Clearance in accordance with local installation codes and the requirements of the gas supplier
I	Clearance to service regulator vent outlet	3 ft. (1.83 m)	Clearance in accordance with local installation codes and the requirements of the gas supplier
J	Clearance to a non mechanical air supply inlet into building or combustion air inlet to any other appliance	<ul style="list-style-type: none"> 6 in (15 cm) for appliances ≤ 10,000 Btuh (3 kW) 12 in (30 cm) for appliances > 10,000 Btuh (3 kW) and ≤ 100,000 Btuh (30 kW) 36 in (91 cm) for appliances > 100,000 Btuh (30 kW) 	<ul style="list-style-type: none"> 4 feet (1.2 m) below or to side of opening; 1 foot (30 cm) above opening
K	Clearance to a mechanical air supply inlet	6 feet (1.83 m)	3 feet (91 cm) above if within 10 feet (3 m) horizontally
L	Clearance above paved sidewalk or paved driveway located on public property	7 feet (2.13 m)†	7 ft. (2.13 m) for mechanical draft systems (Category I appliances); vents for Category II and IV appliances cannot be located above public walkways or other areas where condensate or vapor can cause a nuisance or hazard
M	Clearance under veranda, porch, deck, or balcony	12 inches (30 cm) ‡	12 inches (30 cm) ‡

1 In accordance with the current CSA B149.1, *Natural Gas and Propane Installation Code*.
 2 In accordance with the current ANSI Z223.1/NFPA 54, *National Fuel Gas Code*.
 † A vent shall not terminate directly above a sidewalk or paved driveway that is located between two single family dwellings and serves both dwellings where it may cause

hazardous frost or ice accumulations on adjacent property surfaces.
 ‡ Permitted only if veranda, porch, deck, or balcony is fully open on a minimum of two sides beneath the floor.

SIDEWALL TERMINATION CLEARANCES OTHER THAN DIRECT VENT

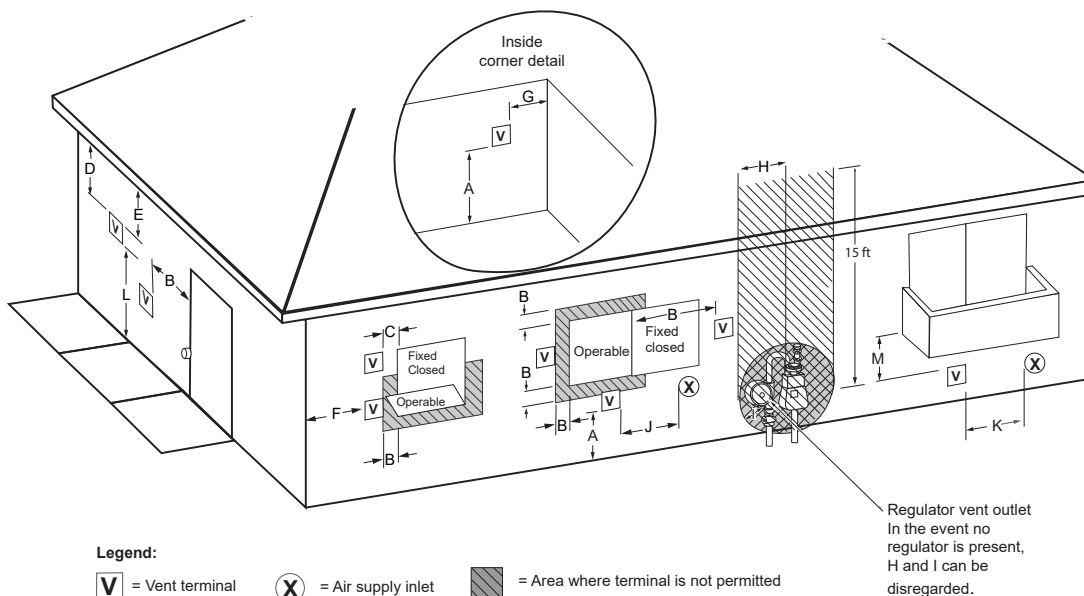

Figure 24. Other than Direct Vent Using Outside Air

Vent terminal clearances for “Direct Vent” installations. Direct Vent configurations use outdoor air for combustion.

Termination Clearances for Sidewall Direct Vent			
	Type of Clearance	Canadian Installations ¹	US Installations ²
A	Clearance above grade, veranda, porch, deck or balcony	12 inches (30 cm)	12 inches (30 cm)
B	Clearance to window or door that may be opened	<ul style="list-style-type: none"> 6 in (15 cm) for appliances ≤ 10,000 Btuh (3 kW) 12 in (30 cm) for appliances > 10,000 Btuh (3 kW) and ≤ 100,000 Btuh (30 kW), 36 in (91 cm) for appliances > 100,000 Btuh (30 kW) 	<ul style="list-style-type: none"> 4 feet (1.2 m) below or to side of opening; 1 foot (30 cm) above opening
C	Clearance to permanently closed window	6 inches (15 cm)*	6 inches (15 cm)*
D	Vertical clearance to ventilated soffit located above the terminal within a horizontal distance of 2 feet (61 cm) from the center line of the terminal	12 inches (30 cm)	12 inches (30 cm)
E	Clearance to unventilated soffit	12 inches (30 cm)	12 inches (30 cm)
F	Clearance to outside corner	2 feet (60 cm)*	2 feet (60 cm)*
G	Clearance to inside corner	18 inches (45 cm)*	18 inches (45 cm)*

Termination Clearances for Sidewall Direct Vent			
	Type of Clearance	Canadian Installations ¹	US Installations ²
H	Clearance to each side of center line extended above meter/regulator assembly	3 ft. (91 cm) within a height 15 ft. (4.6 m)	Clearance in accordance with local installation codes and the requirements of the gas supplier
I	Clearance to service regulator vent outlet	3 ft. (1.83 m)	Clearance in accordance with local installation codes and the requirements of the gas supplier
J	Clearance to a non mechanical air supply inlet into building or combustion air inlet to any other appliance	<ul style="list-style-type: none"> 6 in (15 cm) for appliances ≤ 10,000 Btuh (3 kW) 12 in (30 cm) for appliances > 10,000 Btuh (3 kW) and ≤ 100,000 Btuh (30 kW) 36 in (91 cm) for appliances >100,000 Btuh (30 kW) 	<ul style="list-style-type: none"> 4 feet (1.2 m) below or to side of opening; 1 foot (30 cm) above opening
K	Clearance to a mechanical air supply inlet	6 feet (1.83 m)	3 feet (91 cm) above if within 10 feet (3 m) horizontally
L	Clearance above paved sidewalk or paved driveway located on public property	7 feet (2.13 m) †	7 ft. (2.13 m) for mechanical draft systems (Category I appliances); vents for Category II and IV appliances cannot be located above public walkways or other areas where condensate or vapor can cause a nuisance or hazard
M	Clearance under veranda, porch, deck, or balcony	12 inches (30 cm) ‡	12 inches (30 cm) ‡

¹ In accordance with the current CSA B149.1, *Natural Gas and Propane Installation Code*.
² In accordance with the current ANSI Z223.1/NFPA 54, *National Fuel Gas Code*.
 † A vent shall not terminate directly above a sidewalk or paved driveway that is located between two single family dwellings and serves both dwellings where it may cause

hazardous frost or ice accumulations on adjacent property surfaces.
 ‡ Permitted only if veranda, porch, deck, or balcony is fully open on a minimum of two sides beneath the floor.

DIRECT VENT DIAGRAM

Direct Vent combustion air intake drains are required in certain situations. See *Direct Vent Air Intake Moisture Protection* (page 30) and the *Figure 25* and *Figure 28* below.

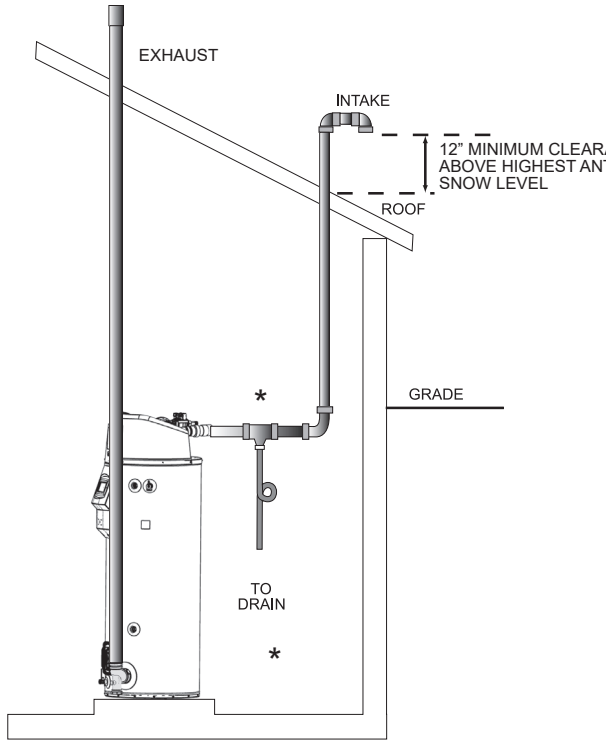

Figure 25. Direct Vent, Pitched Roof, Standard Termination

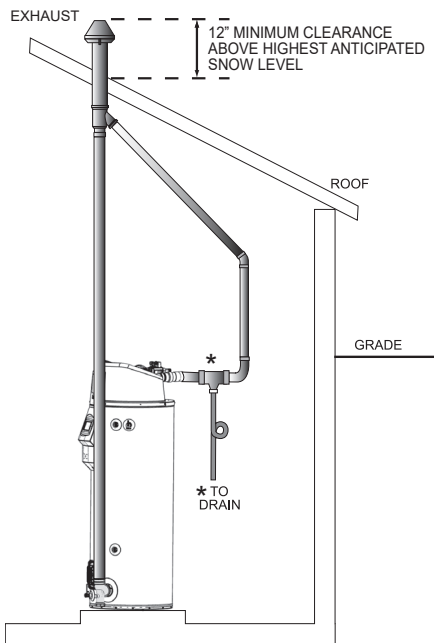

Figure 26. Direct Vent Roof Vent Concentric

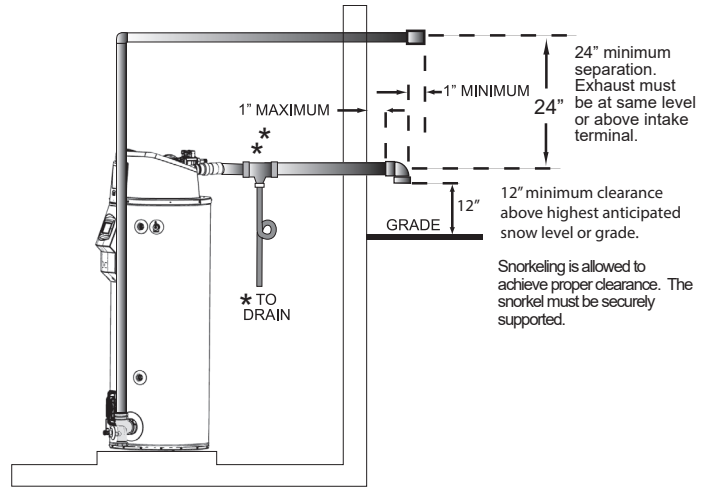

Figure 27. Sidewall Vent - Typical

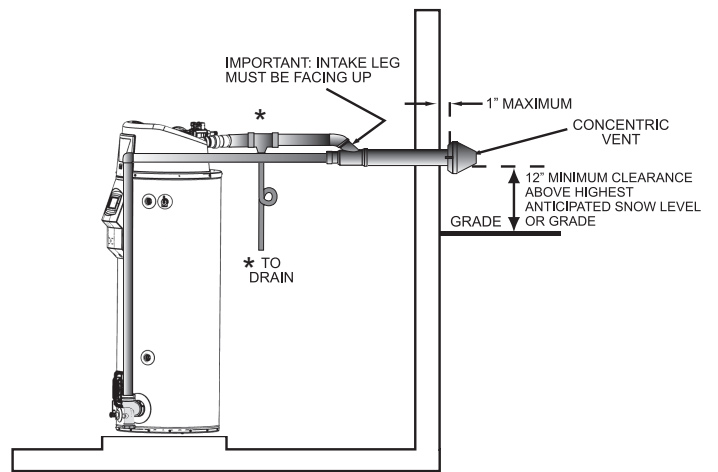

Figure 28. Sidewall Vent - Concentric

LOW PROFILE TERMINATION INSTALLATION

This water heater is certified for sidewall direct venting with IPEX System 636 Low Profile Vent Kit. Follow instructions below for proper installations.

All termination kits must be located and installed in accordance with local codes or the current edition of the *Natural Gas and Propane Installation Code (CSA B149.1)*.

1. Once the proper location has been determined, cut 2 holes in the wall large enough to accommodate the pipe. Pipe diameters and distance between hole centers can be found in **Table 8** (page 35).
2. Slide both the intake and exhaust pipes through the holes. Solvent cement both pipes to the base of the vent termination kit, follow the solvent cementing procedures outlined in the *IPEX System 636 Installation Guide*, which is available on the web www.ipexinc.com.
3. To fasten the Base to the wall, use the supplied screws and anchors. A 3/16" (5 mm) hole, 1-3/16" (30 mm) deep, will need to be drilled for the anchors. Locate the anchor hole using the base as a template.
4. Screw the Cap to the Base using the supplied screws.
5. Once the vent termination and pipes are secured, the wall penetrations will need to be sealed from the interior using a PVC-compatible sealant material.
6. All vent pipes and air inlets must terminate at the same height to avoid possibility of severe personal injury, death, or substantial property damage.
7. Operate heater through one heat cycle to ensure combustion-air and vent pipes are properly connected to concentric vent termination connections.

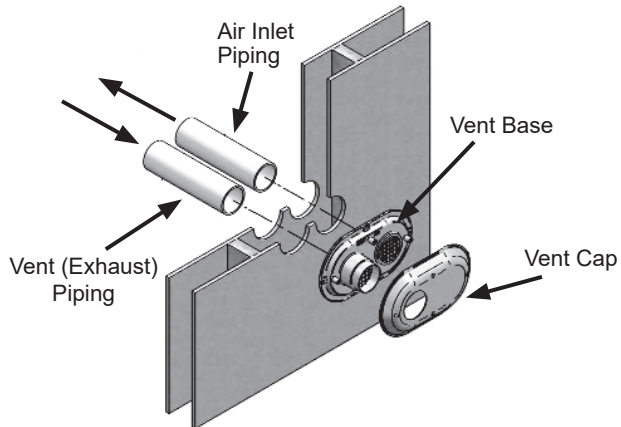

Figure 29. Low Profile Air Inlet/Exhaust Termination

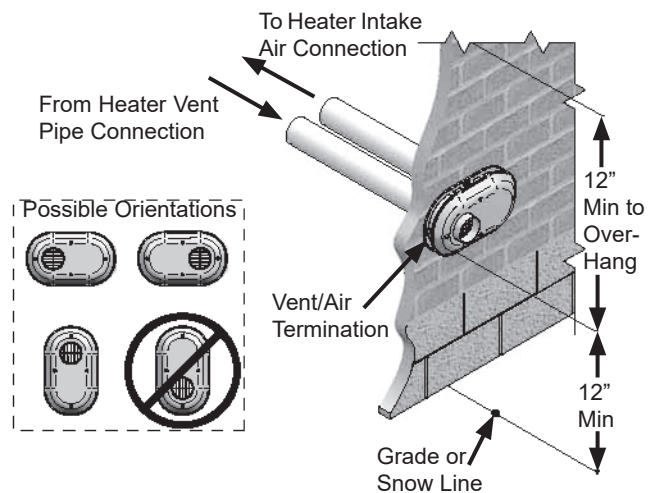

Figure 30. Low-Profile Vent Clearances

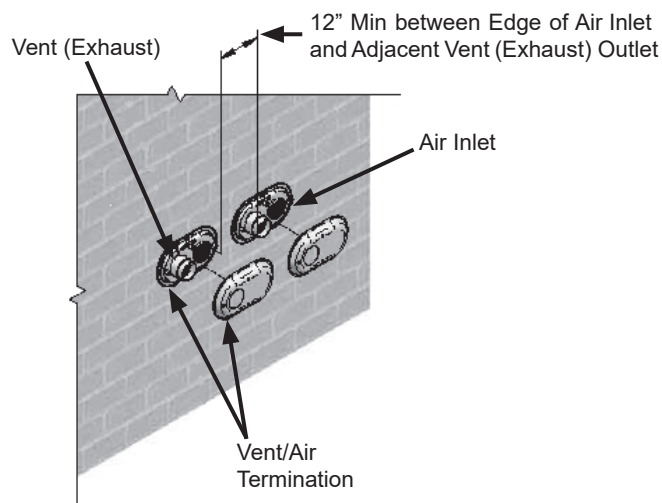

Figure 31. Multiple Low-Profile Vent Termination Configuration

AOS Kit Number	IPEX Part Number	Description	Pipe Outside Diameter	Hole Spacing (ctr to ctr)
100187903	196984	2" Flush Mount Vent Kit	2.375"	5.6"
100187887	196985	3" Flush Mount Vent Kit	3.5"	5.6"

Qty	Item Description
1	Base (two holes)
1	Cap (one hole)
8	Stainless Steel Screws
4	Plastic Anchors

WATER HEATER INSTALLATION

CONDENSATE DRAIN INSTALLATION

Installation must conform with these instructions and local building codes.

Field-supplied materials required for installation include:

- Approved PVC cement and PVC primer.
- 1/2 inch PVC pipe - minimum length to equal the distance between the water heater and a suitable building drain.
- 1/2 inch PVC fittings (elbows, couplings, and adapters) necessary to install a condensate drain line between the Exhaust/Condensate Elbow Assembly and a suitable building drain.
- Floor mounted standoffs to brace the drain line.

Installation Notes

1. The condensate drains from the water heater's covered by this instruction have pH levels between 4.3 and 5.0. Install a commercially available neutralizing kit if required by local codes. Lower pH levels are acidic. Do not connect a metal condensate drain line, such as copper pipe, to the water heater for this reason.
2. The field-installed condensate drain line must not be less than 1/2 inch PVC in size.

3. The exhaust elbow has a built in condensate trap. **Do not install an additional trap in the condensate drain piping. Do not remove, modify or alter the factory condensate trap.**

Installation Instructions

1. Ensure the water heater's Enable/Disable switch is in the "Disable" position.
2. Install a 1/2 inch PVC condensate drain line between condensate drain connection on the Exhaust/Condensate Elbow and a suitable building drain. The condensate line must slope to an open drain. See **Figure 28**.
3. Terminate the condensate drain piping near the drain. See Figure 28.
Note: In cold climates it is recommended the condensate drain be terminated at a suitable drain inside the building.
4. Ensure the condensate drain line is not elevated above the condensate drain connection on the Exhaust/Condensate Elbow. See **Figure 28**.
5. Brace the condensate drain line with floor-mounted standoffs every three feet.
6. Ensure that the condensate drains freely during start up. See **Start Up** (page 39).
7. Condensate clean out cap must be on and tight when unit is in operation.

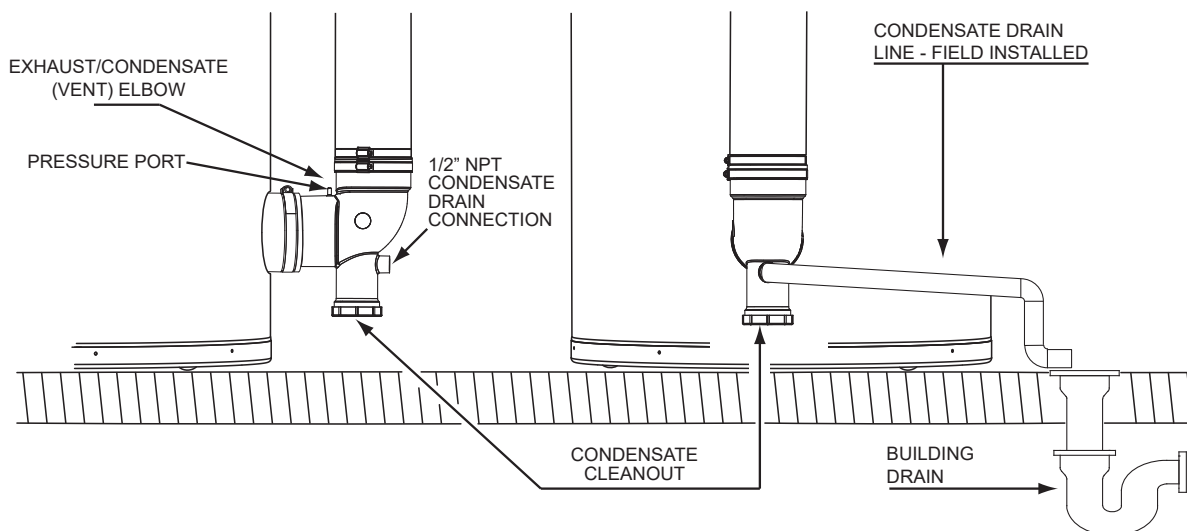



Figure 32. Condensate Drain Installation

GAS PIPING

Make sure gas supplied is same type listed on model rating plate. The inlet gas pressure must not exceed 14 inch water column (3.5 kPa) for natural and propane gas (LP). The minimum inlet gas pressure shown on rating plate is that which will permit firing at rated input.



Schedule 40 Steel or Wrought Iron Pipe is the preferred material for the gas line of this water heater. It is imperative to follow the sizing recommendations in the latest version of the National Fuel Gas Code if Corrugated Stainless Steel Tubing (CSST) is used as the gas line for this water heater.

SEDIMENT TRAPS

 WARNING	
Fire and Explosion Hazard	
	<ul style="list-style-type: none"> Contaminants in gas lines can cause fire or explosions. Clean all gas piping before installation. Install drip leg in accordance with NFPA 54 or CSA-B1491.

A sediment trap shall be installed as close to the gas inlet of the water heater as practical at the time of water heater installation. The sediment trap shall be either a tee fitting with a capped nipple in the bottom outlet or other device recognized as an effective sediment trap.

Contaminants in the gas lines may cause improper operation of the gas control valve that may result in fire or explosion. Before attaching the gas line be sure that all gas pipe is clean on the inside. To trap any dirt or foreign material in the gas supply line, a sediment trap must be incorporated in the piping. The sediment trap must be readily accessible. Install in accordance requirements in *Gas Piping*. Refer to the current edition of the *National Fuel Gas Code (ANSI Z223.1/NFPA 54)* or the *Natural Gas and Propane Installation Code (CAN/CSA B149.1)*.



 WARNING	
Fire and Explosion Hazard	
	<p>Gas piping can leak gas from fittings and connections if it is not sealed properly. Gas leaks can cause fires and explosions resulting in severe injury or death.</p> <ul style="list-style-type: none"> Use joint compound or thread sealer tape compatible with the type of gas you are using. Leak test all gas connections before placing the water heater in operation. Disconnect gas piping at main gas shutoff valve before leak testing. Install sediment trap in accordance with NFPA 54 or CAN/CSA B149.1.

Use pipe joint compound or thread sealer tape marked as being resistant to the action of petroleum [Propane (LP)] gases.

The water heater and its gas connection must be leak tested before placing the water heater in operation.

The water heater and its individual Shut-off valve shall be disconnected from the gas supply piping system during any pressure testing of that system at test pressures in excess of 1/2 pound per square inch (3.5

kPa). It shall be isolated from the gas supply piping system by closing its individual manual Shut-off valve during any pressure testing of the gas supply piping system at test pressures equal to or less than 1/2 pound per square inch (3.5 kPa).

 WARNING	
Fire and Explosion Hazard	
	<p>An improper field conversion from one type of gas to another could cause potentially dangerous conditions that may cause an explosion or fire resulting in property damage, bodily injury or death.</p> <p>Do not attempt to convert a water heater without consulting A. O. Smith.</p>

ELECTRICAL WIRING

All electrical work must be installed in accordance with the *National Electrical Code, ANSI/NFPA 70* or the *Canadian Electrical Code, CSA C22.1* and local requirements.

When installed, the water heater must be electrically grounded in accordance with local codes or, in the absence of local codes, with the *National Electrical Code, ANSI/NFPA 70* or the *Canadian Electrical Code, CSA C22.1*.

If any of the original wire as supplied with the water heater must be replaced, it must be replaced with 105°C rated wiring or its equivalent, except in the burner housing. In this case 200°C rated wire must be used.

DEDICATED POWER WIRING AND BREAKERS

Dedicated power supply wires, neutral wires, ground wiring, and dedicated circuit breakers often prevent electrical line noise and are required when installing the water heater.

Note: This water heater should not be connected to an electrical supply with a Ground Fault Circuit Interrupter (GFCI) or Arc Fault Circuit Interrupter (AFCI) with Integral GFCI protection as defined in *NFPA 70, CSA C22.1* and *UL 943*.

Read the requirements in *Power Supply* (page 20) before connecting power.

Enable / Disable Circuit

The water heaters covered in this manual are equipped with an enable/disable circuit for use with field-supplied external supervisory controls, such as time clocks or Building Management Systems. The enable/disable circuit may be used to disable heating operation during periods when the building is unoccupied or there is no demand for hot water.

To use the enable/disable circuit, it must first be activated by selecting the "Use External Enable" from the UIM. Field-supplied wiring is then installed between the water heater's control board enclosure and a set of "dry contacts" (no voltage or load) on the field-supplied external control.

Note: The water heater's enable/disable circuit is a switching circuit only: Do not apply external voltage or connect any load (i.e., relay coil) to this circuit. This will damage the circuit board and is not covered

under the limited warranty. See the Residential Water Heater Limited Warranty supplied with this water heater.

Note: Ensure the water heater is protected from freezing temperatures when water heating operation is disabled. Damage to the water heater caused by freezing temperatures is not covered under the limited warranty. See the Residential Water Heater Limited Warranty supplied with this water heater.

LEAK DETECTION MODULE

The water heaters covered by this manual have a water leak protection feature that senses the buildup of water in the vicinity of the appliance, setting off an alarm to alert the end user. Please follow installation instructions in included kit.

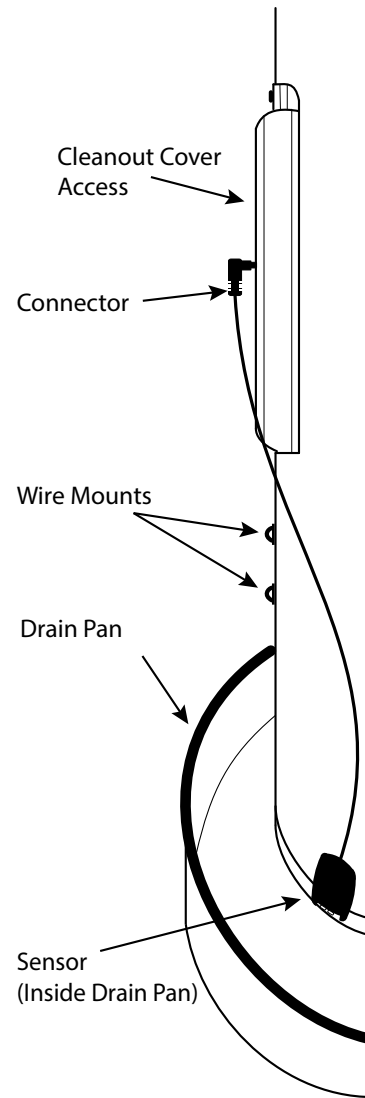

Figure 33. Installation of Leak detection Module

START UP

PRIOR TO START UP

Installation and start up of this water heater requires abilities and skills equivalent to that of a licensed tradesman in the field involved, see Qualifications on page 7.

DO NOT USE THIS APPLIANCE IF ANY PART HAS BEEN EXPOSED TO FLOODING OR WATER DAMAGE. Immediately call a qualified service agency to inspect the appliance and to make a determination on what steps should be taken next. If the unit is exposed to the following, do not operate heater until all corrective steps have been External fire

1. Damage
2. Firing without water

Light the water heater in accordance with the Lighting and Operation Instruction label on the water heater and in this manual Lighting the Water Heater on page 49.

The water heaters covered by this manual are equipped with an electronic control system, which automatically sequences the Combustion Blower, pre and post purging of the combustion chamber, the spark transformer, the gas valve, Main Burner ignition, and flame sensing. The control system will lock out after three unsuccessful ignition attempts. See Control System Operation on page 41.

Start-Up Preparation

Before attempting start up, thoroughly study and familiarize yourself with the exact Sequence Of Operation (page 54). Ensure the water heater is properly grounded. Flame sensing requires an adequate earth ground. If the water heater is not properly grounded it will cause ignition failure.

Be certain that the water heater is full of water, that air is purged from the gas and water lines and that there are no leaks in the gas and water lines. Ensure all inlet water valves are open.

Filling the Water Heater

CAUTION

Property Damage Hazard

To avoid water heater damage, fill tank with water before operating.

Never use this water heater unless it is completely full of water. To prevent damage to the tank, the tank must be filled with water. Water must flow from the hot water faucet before turning ON gas to the water heater.

To fill the water heater with water:

1. Close the water heater drain valve by turning the handle to the right (clockwise). The drain valve is on the lower front of the water heater.
2. Open the cold water supply valve to the water heater.
Note: The cold water supply valve must be left open when the water heater is in use.
3. To insure complete filling of the tank, allow air to exit by opening the nearest hot water faucet. Allow water to run until a constant flow is obtained. This will let air out of the water heater and the piping.
4. Check all water piping and connections for leaks. Repair as needed.

GAS CALIBRATION

At the initial start up of the heater, an initial calibration routine must run. This initial calibration may take up to 15 minutes.

During this initialization, any burner heat demand will be blocked.

After calibration, the continuous monitoring function becomes active. This function can trigger a new calibration in case a gas quality change is detected or there is a manual intervention by the qualified service technician.

1. Click 'Confirm' to proceed with the calibration.

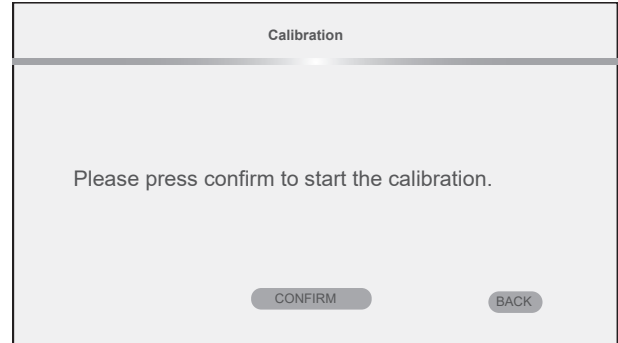

2. Set the date and time, then click Confirm to continue with the calibration.

Calibration will begin and progress screen will display.

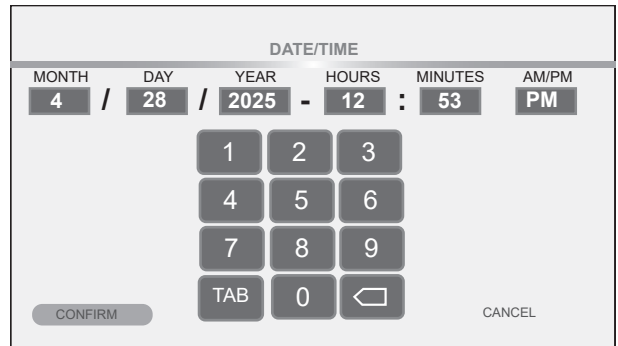

3. Click Confirm to begin the calibration process.

Note: Calibration may take up to 15 minutes.

When the calibration is complete, you will be returned to the home screen.

It is normal for the first ignition following the calibration process to be rough.

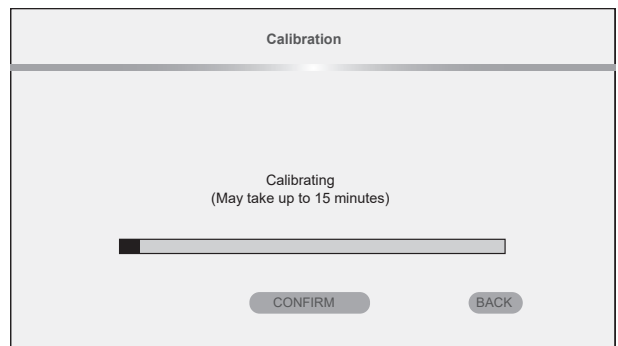

LIGHTING INSTRUCTIONS

The instruction label below is affixed to the water heaters that are covered by this manual at the factory and must be followed when lighting and operating the water heater.

FOR YOUR SAFETY READ BEFOR LIGHTING



WARNING: If you do not follow these instructions exactly, a fire or explosion may result causing property damage, personal injury, or loss of life.



BEFORE OPERATING: ENTIRE SYSTEM MUST BE FILLED WITH WATER AND AIR PURGED FROM ALL LINES

A. This appliance does not have a pilot. It is equipped with an ignition device which automatically lights the burner. Do not try to light the burner by hand.

B. BEFORE OPERATING, smell all around the appliance area for gas. Be sure to smell next to the floor because gas is havier than air and will settle to the floor.

“WHAT TO DO IF YOU SMELL GAS”

- Do not try to light the appliance.
- Do no touch any electrical switch; do not use any telephone in your building.
- Immediately call your gas supplier from a neighbor’s phone. Follow the gas supplier’s instructions.

- If you cannot reach your gas supplier, call the fire department.

C. Use only your hand to push in the control buttons. Never use tools. If the control buttons will not push in, don’t try to repair them, call a qualified service technician. Force or attempted repair may result in fire or explosion

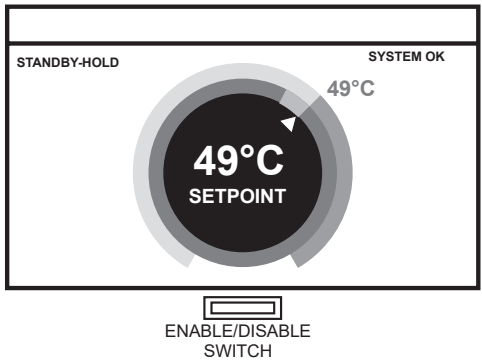

D. Do not use this appliance if any part has been under water. Immediately contact a qualified installer or service agency to replace a flooded water heater. Do not attempt to repair the service unit. It must be replaced.

OPERATING INSTRUCTIONS



ENABLE/DISABLE SWITCH

1.  STOP! Read the safety information above on this label
2. Set the Enable/Disable switch on the control panel to the Enable position.
3. Set the thermostat to the lowest setting.
4. Set the Enable/Disable switch on the control panel to the Disable position.

5. This appliance is equipped with a device which automatically lights the burner. **DO NOT TRY TO LIGHT THE BURNER BY HAND.**
6. Wait five (5) minutes  to clear out any gas. If you then smell gas,  STOP! Follow “B” in the safety information above on this label. If you don’t smell gas, go to the next step.
7. Turn on all electrical power to the appliance.
8. Set the Enable/Disable switch on the control panel to the Enable position.
9. Set the thermostat to the desired setting.

CAUTION: Hotter water increases the risk of scald injury. Consult the instruction manual before changing temperature

10. If the appliance will not operate, follow the instructions “TO TURN OFF GAS TO APPLIANCE” and call your technician or gas supplier.

WARNING: TURN OFF ALL ELECTRIC POWER BEFORE SERVICING.

TO TURN OFF GAS TO APPLIANCE

1. Set the thermostat to the lowest setting.
2. Set the Enable/Disable switch on the control panel to the Disable position.
3. Turn off all electrical power to the appliance if service is to be performed.

Figure 34. Lighting Instructions Label

TEMPERATURE REGULATION

LIMITING THE RISK OF SCALDING

For a variety of reasons, water heaters can produce water that is much hotter than its temperature setting. Take precautions to prevent this higher temperature water from reaching the water fixtures.

⚠ WARNING	
Burn Hazard	
	<p>The temperature of the water in the water heater can exceed the thermostat setting and be hot enough to cause burns.</p> <p>To reduce the risk of unusually hot water reaching the fixtures in the house, install point of use thermostatic mixing valves at each point of use.</p>

According to a national standard, *Performance Requirements for Water Temperature Limiting Devices (ASSE 1070)* and many local plumbing codes, the water heater's gas control valve should not be used as the sole means to regulate water temperature and avoid scalds.

A properly adjusted thermostatic mixing valve at each point of use allows you to set the tank temperature to a higher setting without increasing risk of scalds. A higher temperature setting allows the tank to provide much more hot water and can help provide proper water temperatures for appliances such as dishwashers and washing machines.

HIGH TEMPERATURE LIMIT CONTROL

This water heater is equipped with a non-adjustable high-temperature limit control.

The high-temperature limit control is located inside the Temperature Probe. See *Figure 1* (page 10) and *Figure 2* (page 11).

If the high-temperature limit control activates due to abnormally high water temperatures in the storage tank, the control system will immediately deenergize the gas valve and end the current heating cycle. The control system will "lock out" disabling further heating operation. The control system will display the "High Temp Limit Exceeded" Fault message on the LCD screen. It is important that a Qualified Service Agent be contacted to determine the reason for the high-temperature limit control activation before resetting the high-temperature limit control. Once the reason has been determined and corrected the high-temperature limit control can be reset as follows:

If the high-temperature limit control activates, the water temperature must drop below 140°F (60°C) before the control system can be reset. Once the water temperature has cooled below this point, the power supply to the water heater must be turned off and on again to reset the control system.

THERMOSTAT CONTROL

⚠ DANGER	
Burn Hazard	
	<p>Because of the increased risk from scalding, if you set the water heater's gas control knob higher than 120°F (49°C), install thermostatic point-of-use mixing valves at each point of use. Due to the increased risk of scalding, do not set the temperature of the thermostatic mixing valves above 120°F (49°C).</p>

Hot water temperatures required for automatic dishwasher and laundry use can cause scald burns resulting in serious personal injury and/or death. *Table 10* (page 43) shows the approximate time-to-burn relationship for normal adult skin.

The temperature at which injury occurs varies with the person's age and duration of exposure. The slower response time of children, the elderly or disabled persons increases the hazards to them. If anyone using hot water provided by the water heater being installed fits into one of these groups or if there is a local code or state law requiring a certain water temperature at the point of use, then special precautions must be taken.

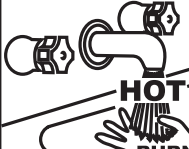
⚠ WARNING	
Burn Hazard	
	<p>The temperature of the water in the water heater can exceed the thermostat setting and be hot enough to cause burns.</p> <p>If you choose a higher temperature setting, install thermostatic mixing valves at each point-of-use to help avoid scalding.</p>

In addition to using the lowest possible temperature setting that satisfies the demand of the application a means, such as a thermostatic point-of-use mixing valve, for example, can be used at the hot water taps used by these people to reduce the water temperature.

Check State and/or local codes for thermostatic point-of-use mixing valve requirements and installation practices.

Never allow small children to use a hot water tap or draw their own bath water. Never leave a child or disabled person unattended in a bathtub or shower.

The water heater should be located in an area where the general public does not have access to set temperatures.

Setting the Operating Set Point at 120°F (49°C) will reduce the risk of scalds. Some States require settings at specific lower temperatures.

Table 10. Time to Burn at Different Temperatures		
Water Temperature °F (°C)	Time for 1st Degree Burn (Less Severe Burns)	Time for Permanent Burns 2nd & 3rd Degree (Most Severe Burns)
110 (43.3)	(Normal shower temp.)	
116 (46.7)	(Pain threshold)	
116 (46.7)	35 minutes	45 minutes
122 (50)	1 minute	5 minutes
131 (55)	5 seconds	25 seconds
140 (60)	2 seconds	5 seconds
149 (65)	1 second	2 seconds
154 (67.8)	Instantaneous	1 second

(U.S. Government Memorandum, C.P.S.C., Peter L. Armstrong, Sept. 15, 1978)

WARNING

Burn Hazard

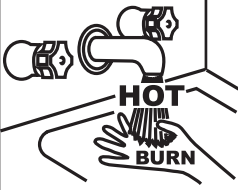

The temperature of the water in the water heater can exceed the thermostat setting and be hot enough to cause burns.

To reduce the risk of unusually hot water reaching the fixtures in the house, install point of use thermostatic mixing valves at each point of use.

The water heaters covered in this manual are equipped with an electronic control system to regulate water temperature inside the storage tank. The control system senses temperature from a factory-installed temperature probe. See **Figure 1** (page 10) and **Figure 2** (page 11) for location.

The “Operating Set Point” is adjusted to regulate water temperature inside the storage tank. This is an adjustable user setting in the control system’s “Temperatures Menu.” This and all control system menus are accessed through the UIM (user interface module) located on the front of the water heater.

The Operating Set Point is adjustable from 90°F (32°C) to 160°F (71°C). The factory setting is 120°F (49°C). See **Set Point Manager** (page 46) for instructions on how to adjust the Operating Set Point and other user settings.

Set the Operating Set Point at the lowest setting that produces an acceptable hot water supply. This will always provide the most energy efficient operation.

HIGH TEMPERATURE APPLICATIONS

Higher operating temperatures cause more wear on all water heaters and will decrease the life span of the water heater. Consider installing a small booster water heater for high temperature applications to raise the outlet temperature from the larger primary water heater to the desired point of use temperature.

Contact your local distributor or call the technical support phone number listed on the back cover of this manual for further technical assistance.

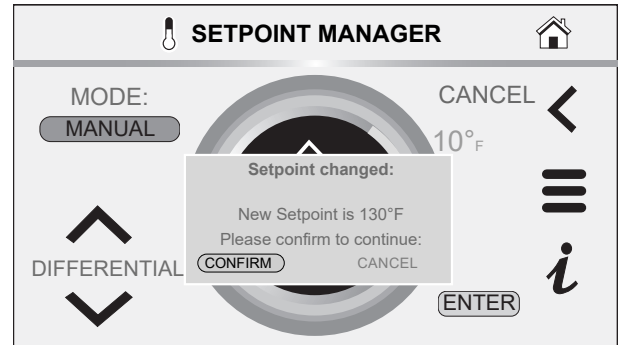
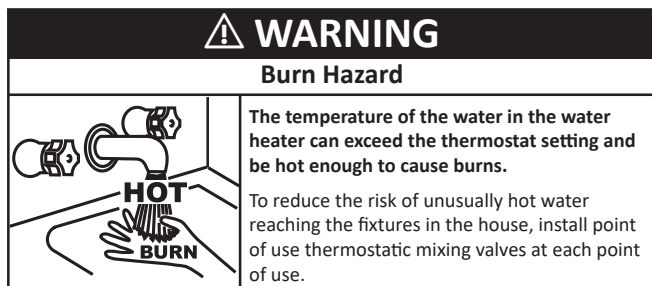

Figure 35. Tank Temperature Set point

CONTROL SYSTEM OPERATION

LIMITING THE RISK OF SCALDING

For a variety of reasons, water heaters can produce water that is much hotter than its temperature setting. Take precautions to prevent this higher temperature water from reaching the water fixtures.



According to a national standard, *Performance Requirements for Water Temperature Limiting Devices (ASSE 1070)* and many local plumbing codes, the water heater's gas control valve should not be used as the sole means to regulate water temperature and avoid scalds.

A properly adjusted thermostatic mixing valve at each point of use allows you to set the tank temperature to a higher setting without increasing risk of scalds. A higher temperature setting allows the tank to provide much more hot water and can help provide proper water temperatures for appliances such as dishwashers and washing machines.

WI-FI

The water heaters covered in this manual feature a Wi-Fi functionality that is enabled at the factory. If Wi-Fi is not required for installation, you can be disabled it as follows:

1. Go to main menu screen
2. Select iCOMM icon
3. Wi-Fi Status should show "AP Mode" (If not scroll down to "Change to AP Mode" line item and Enable)
4. Enable the Wi-Fi if it is showing as disabled
5. Using a phone or tablet go to the Wi-Fi settings and search available networks
6. In the list of networks, there should be a name that is similar to "iCOMMNextGenUIM-XXXXXXX". This is the website being broadcast by the display on the water heater. Select this network.
7. After selecting the iCOMM network, a separate message may appear asking for permission to Stay Connected to the selected network. Select the option to stay connected. Under the selected network name, there should be an indication that the Wi-Fi connected with the above iCOMM network.
8. Open a new Internet browser window on the device.
9. The Internet browser may automatically go to the web address 192.168.0.1. If it doesn't, type that number into the address bar. This will bring up a page that looks similar to the following:
10. Find the network name on the left that corresponds to the local Wi-Fi network, and select the Connect button to the right of it.
11. If the local network is password protected, a new screen will appear asking for the password. Enter the password for the local network and click Connect.

12. A confirmation message should appear indicating the Connection to Wi-Fi was completed.

LOCKOUT FUNCTION

The water heaters covered in this manual feature a lockout functionality that is disabled at the factory by default. If the lockout functionality is required by the end user, the initial installer/contractor can access this functionality and enable it through the UIM. See *Lockout Function* (page 54) for the procedure.

CONTROL SYSTEM OVERVIEW

The water heaters covered in this manual are equipped with an electronic control system that regulates water temperature inside the storage tank. Heating cycles and ignition are managed by the control system. The high-temperature limit control, flame sensor, pressure switches, and temperature probes are monitored by the control system. The combustion blower, spark ignition transformer, gas valve and anode rods are all powered by the control system.

The main components of the control system are a user interface module (UIM), Temperature Regulation Control (TRC) and control system circuit (CSC). The UIM is located on the top front side of the water heater. The control boards are mounted on top of the water heater inside a protective enclosure. This unit is equipped with an Enable/Disable switch. To operate unit, make sure the switch is set to Enable. See *Features and Components* (page 10) for location of these and all water heater components.

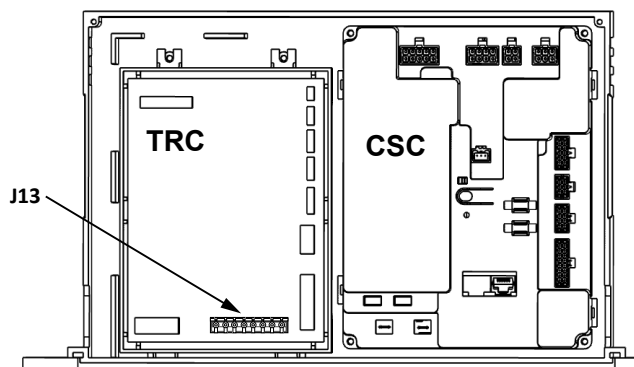

Figure 36. Control System Components

CONTROL SYSTEM NAVIGATION

All operational information and user settings are displayed and accessed from the UIM. The UIM houses the control system's LCD Touch Display (liquid crystal display).

The Home Screen

During normal operation, the control system displays the Home screen on the LCD Touch Display, which is the default screen. The control system returns to the Home screen when there are no active fault or alert conditions or when there has been no user input for several minutes.

- Manufacturer and water heater model information displays in the Title Bar at the top of the Home screen.

- The Operating set point is shown in the middle of the Home screen. This is the temperature at which the control system will maintain the water inside the storage tank.
- Status is shown in the upper left. The status shows the current operational state of the control system in real time.
- The light green band on the temperature dial shows the temperature offset.
- The three horizontal lines on the Home screen will allow you to access sub menus.
- The Home screen also displays animated status icons to convey operational information. See **Table 11** (page 45) for descriptions of the status icons.

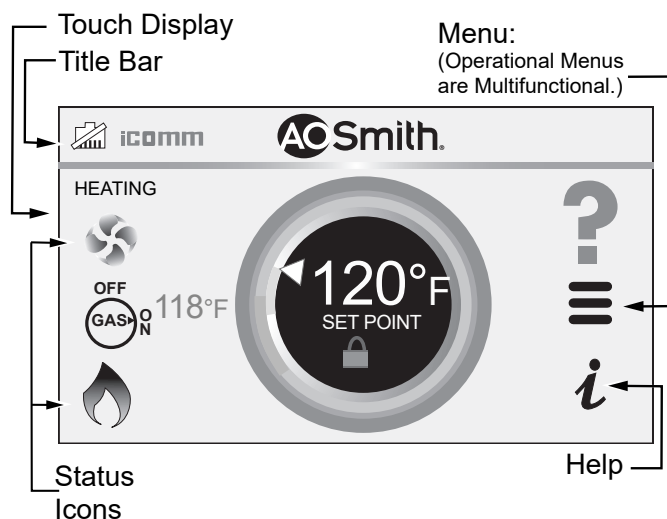

Figure 37. User Interface Module (UIM) Home Screen

Status Icons

The Status Icons are displayed on the Desktop screen and convey operational and diagnostic information. The icons are described in the table below.

Table 11. Status Icons	
Icon	Description
	The Combustion Blower is energized.
	The gas valve is being energized.
	The control system has sensed flame at the Main Burner from the flame sensor. See Figure 42 (page 62) and Figure 2 (page 11).
	The control system has declared a fault condition and must be inspected/serviced by a Qualified Service Agent. Fault message details can be viewed in the Current Fault menu. Heating operation is disabled (lock out) until the condition that caused the fault is corrected. Power to the water heater must be cycled off and on at the breaker to reset the control system. Note: Cycling power will not reset the control system if the condition that caused the fault has not been corrected.
	The control system has declared an alert condition and must be inspected/serviced by a Qualified Service Agent. The water heater will continue to operate during an alert condition.

Operating States

The current operational state of the water heater is displayed on the Desktop screen as the "Status." The common operational states are described in the table below.

Table 12. Operating States	
State	Description
Uncalibrated	The unit is currently uncalibrated and must go through calibration before use.
Calibration	The unit is currently going through calibration procedure.
Standby	Heater is waiting on a call for heat.
Initializing	Initializing heater before regular heating.
Input Verification	The unit has begun a burn cycle and is checking all safety circuits.
Pre-Purge	The unit has begun a spark period to ignite the main burner.
Ignition	The unit has begun a burn cycle and is checking safety circuits.
Inter-Purge	After a failure to ignite the burner, the control is attempting to purge any excess gas from the heater exchanger before another attempt to light.
Heating	The water heater has been properly lit, and the water in the tank is being heated.
Post-Purge	Combustion products are being pushed out of the heater exchanger after a successful heating cycle.
System in Fault	The water heater control has detected a fault. No further heating of the water will be done until reset.
Blocked	A condition is preventing a burn cycle that must clear before resuming water heating.
Ext Ena	External enable/disable switch is active on unit.
BMS	BMS is active on unit.
Heater Disabled	The heater has been disabled and will not heat water.

Control System Menus

From the Desktop screen pressing "Menu" on the LCD Touch Display will display the "Main Menu" this is where all control system menus are located. The table below describes the control system menus.

Table 13. Control System Menus	
Menu	Description
Setpoint Manager	Most commonly accessed menu. Contains the Operating Setpoint and Differential user settings.
Heater Status	This menu displays the current state of all pressure switches and the high temperature limit control sensors. The on/off status of the Combustion Blower, gas valve, igniter, flame sensor and other monitored water heater components are displayed in this menu.
Display Settings	Temperature units (°F or °C), the LCD appearance (brightness/contrast) and back-light delay user adjustable settings are located in this menu.
Heater Information	Elapsed time of operation, total heating cycle time, heating cycle count, heating on time along with UIM and control board software revisions can be viewed in this menu.
Current Fault	Displays any current alert or fault messages.
Fault History	This control system menu retains a list of the last nine (9) fault and alert messages with a time stamp. The newest event will replace the oldest. Faults will clear after 30 days.
Fault Occurrence	This control system menu retains a running total of how many times each fault condition has occurred since the water heater was first installed. The data does not clear and cannot be reset.
Restore	This control system feature allows the user to restore control system user settings to their factory default settings. Display Settings preferences ARE NOT changed when factory defaults are restored.
Help Screens	Text based operational and user information explaining how to change user settings, navigate the control system menus and icon descriptions.
Disabled	The heater has been disabled and will not heat water.

USER SETTINGS & CONTROL SYSTEM MENUS

Operating Set-Point and Differential Adjustment

The Operating Set Point is adjustable from 90°F (42°C) to 180°F (82°C). The factory setting is 120°F (49°C). The Differential is adjustable from 2°F (1°C) to 20°F (11°C). The factory setting is 8°F (4°C). These user settings are accessed from the Temperatures menu. The following instructions will explain how to adjust these settings and navigate the control system menus.

When the water temperature sensed by the control system from the Main Temperature Probe reaches the Operating Set Point, the control system ends the heating cycle. A heating cycle will be activated again when the sensed water temperature drops below the Operating Set Point minus the Differential setting.

⚠ WARNING

Burn Hazard

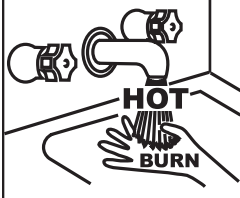

The temperature of the water in the water heater can exceed the thermostat setting and be hot enough to cause burns.

If you choose a higher temperature setting, install thermostatic mixing valves at each point-of-use to help avoid scalding.

Note: Lower Differential settings may cause excessive heating cycles (short-cycling) which can cause premature failure of heater components. Set the Differential at the highest setting which produces an acceptable hot water supply. Set the Operating Set Point to the lowest setting which produces an acceptable hot water supply for most efficient use.

Set Point Manager

From the Set Point Manager, you can adjust the Differential Mode and the Differential.

- From the Home screen, press MENU icon. The "Main Menu" screen will be displayed.

Note: The differential is indicated by the light green band on the temperature dial.

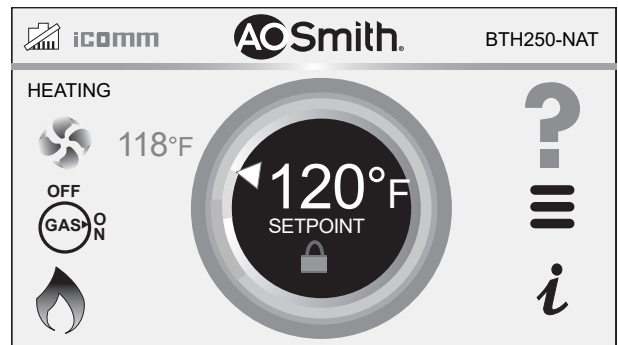

The Main Menu is where all control system menus are listed. See **Table 13** (page 46) for a complete list and description of control system menus.

- Press Heater Menu to access the Setpoint Manager Menu.

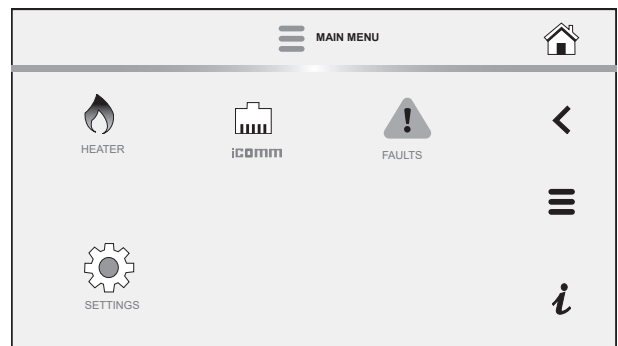

- Press Heater: Setpoint Manager to access the temperature setpoint menu.
- Use the arrow Buttons to change the current setting.

Note: Higher Temperature settings increase wear and operating costs. Set the Operating Set Point to the lowest setting which produces an acceptable hot water supply. This will always provide the most energy efficient operation and longer life.

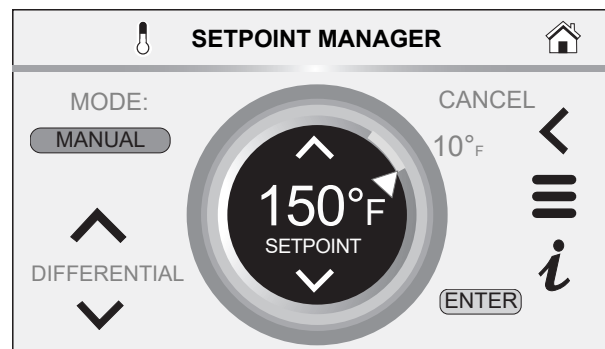

- Tap "CONFIRM" to save the new setting. Press "CANCEL" to discard changes and return to the previously saved setting.

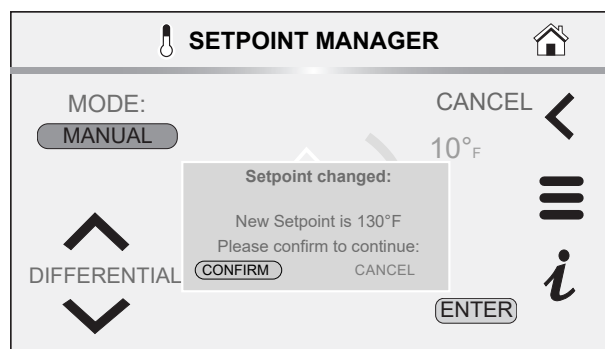

- To change the differential setting: change the mode from automatic to manual, then use the up and down arrows on the differential to change setting. Confirm to keep changes or Press the Cancel button to return to the previously saved settings.

- Differential Mode** - Operating mode with an Intelligent Demand Response (IDR). This mode allows the water heater to reduce preset differential to a lower setting so that the appliance will more rapidly respond to large draws to maintain water outlet temperature. This mode is enabled at the factory by default, but can be disabled in the field if required.
- Differential** - Adjustable user setting that changes the tank temperature differential with a range of 2° to 20°F. The factory setting is 8°F.

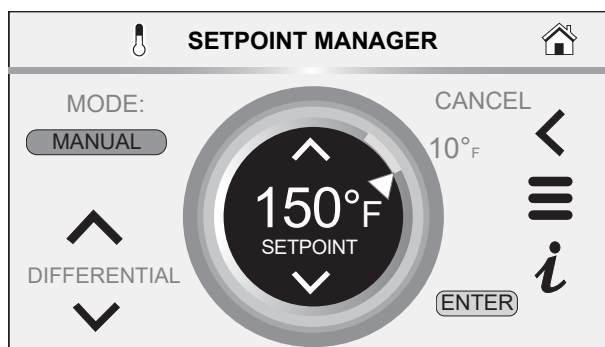

These settings are adjusted in the same way described in **Operating Set-Point and Differential Adjustment** (page 46).

iCOMM Menu

- From the Home screen, press MENU icon.
The "Main Menu" screen will be displayed.
- Press the iCOMM icon to access the iCOMM screen.

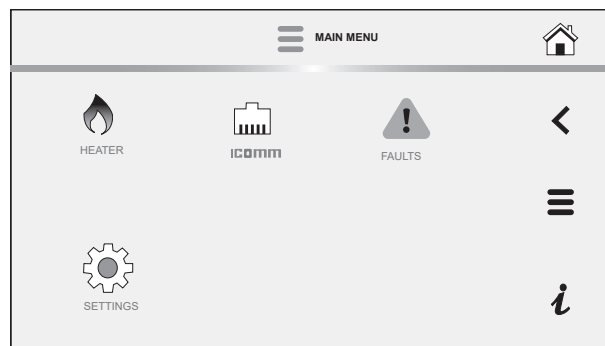

The iCOMM screen displays the following Wi-Fi information:

- **Wi-Fi Status** - displays status of Wi-Fi connection.
- **Ethernet** - displays status of Ethernet connection.
- **iCOMM Server** - displays status the iCOMM server.
- **Wi-Fi MAC** - displays the Wi-Fi MAC number.
- **Ethernet MAC** - displays the Ethernet MAC number.
- **DSN** - displays the Device Serial Number (DSN). Used for registration of the heater.
- **Wi-Fi Strength** - displays Wi-Fi signal strength as a series of bars.
- **Wi-Fi Strength** - displays Wi-Fi signal strength dBm units.

Wi-Fi - Wi-Fi functionality is enabled at the factory. In the bottom portion of the menu, the Wi-Fi can be disabled by selecting the **Enabled** marker and selecting the **Disable** option. This is the only item on this screen that can be adjusted. The other items are for view and information purposes only.

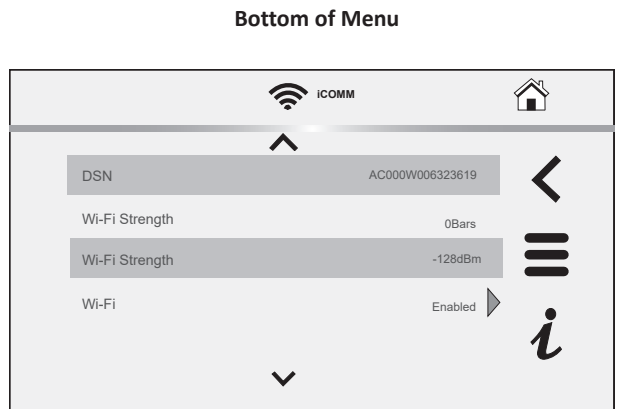
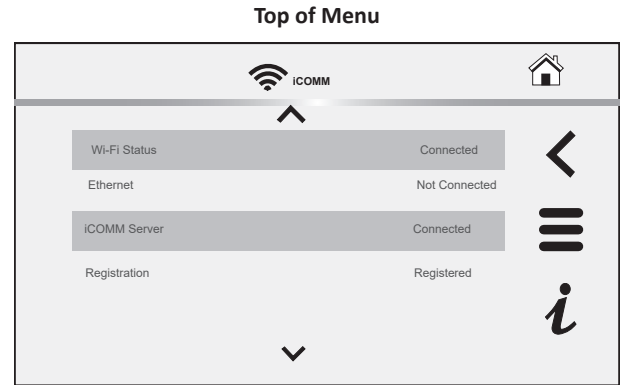

Heater Information Menu

1. From the Home screen, press MENU icon.
The "Main Menu" screen will be displayed.
2. From the Main Menu, press the Heater icon to access the Heater menu.

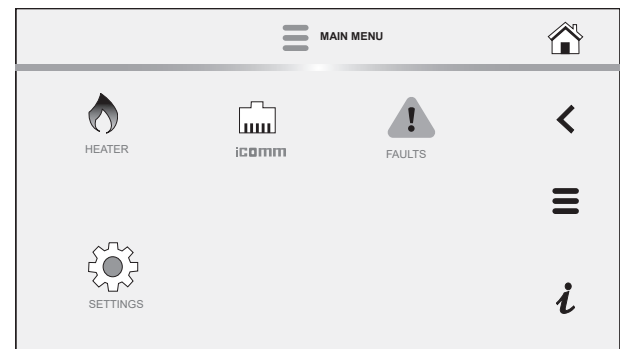

3. Press the Heater Information icon from the Heater menu to enter the Heater Information screen.

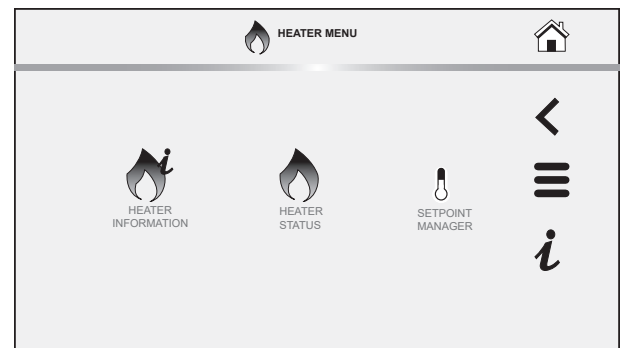

This screen contains non adjustable operational information.

- **Elapsed Time** - Total accumulated time the control system (water heater) has been energized.
- **Total Heat Time** - Total accumulated time the control system has been in the heating operating state; burner run time.
- **Total Cycle Counter** - Total accumulated count of heating cycles.
- **Ignition Failure Count** – Total accumulated count of ignition failures.
- **Flame Loss Count** - Total accumulated count of flame losses.
- **TRC Version** - Software version for TRC board.
- **UIM Version** - Software version for user interface module.
- **Serial Number** - Serial number of the water heater.
- **Model Number** - Model number of the water heater
- **CSC Version** - Software version for CSC board.
- **CPAM1 Version** - Software version for CPAM1.
- **CPAM2 Version** - Software version for CPAM2.
- **Building Management Version** - Software version for Building Management System.
- **Water Valve Control Version** - Software version for the water valve control.
- **NANODE Version** - Software version for NANODE.

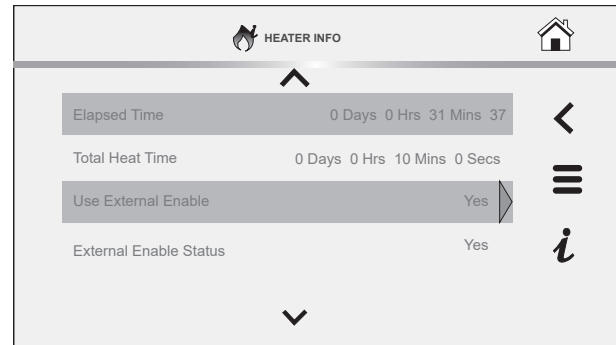

Historical data is stored in the NFC board key. If this board is removed or damaged during servicing the historical data will be lost and heater will no longer operate. The NFC board key should never be replaced unless directed by Technical Support.

The Elapsed Time, Burner On Time and Cycle Count indicate age, usage and wear.

If the Cycle Count per day is high (divide cycle count by days to determine cycles per day) or the cycle duration is short (determine burner on time total minutes, divide burner on time total minutes by cycle count) consider raising the Differential setting to avoid short cycling and excessive component wear. See **Operating Set-Point and Differential Adjustment** (page 46).

This historical data can also be used to assist facilities managers in forecasting planned replacement of equipment to help avoid lengthy and costly hot water supply interruptions.

Heater Status Menu

1. From the Home screen, press MENU icon.
The "Main Menu" screen will be displayed.
2. From the Main Menu, press **Heater: Heater Information** to access the Heater Information screen.

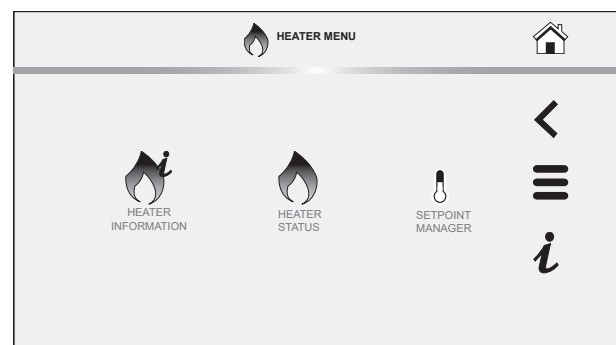

The Heater Status menu displays the following information:

- **Status** - Indicates whether the heater is Enabled or Disabled.
- **Blocked Inlet PS** - Indicates if the Inlet is blocked.
- **Blocked Outlet PS** - Indicates if the Outlet is blocked.
- **Igniter On** - Indicates if the Igniter is operational
- **Gas Valve On** - Indicates if the gas valve is on.
- **Flame Detected** - Indicates if flame is detected.
- **Blower RPM** - Indicates the blower RPMs
- **Main Temperature** - Temperature reading of the main temperature probe.
- **Lower Temperature** - Temperature reading of the lower temperature probe.
- **Anode Current** – Current reading of anode
- **Anode Tank Voltage** – Voltage of anode tank
- **Anode Drive Voltage** – Voltage of anode drive
- **Water Valve 1 Status** – Current status of Water Valve 1
- **Water Valve 1 Error** – Error in Water Valve 1
- **Water Valve 2 Status** - Current status of Water Valve 2
- **Water Valve 2 Error** - Error in Water Valve 2
- **Water Valve 3 Status** - Current status of Water Valve 3
- **Water Valve 3 Error** - Error in Water Valve 3

Top of Menu

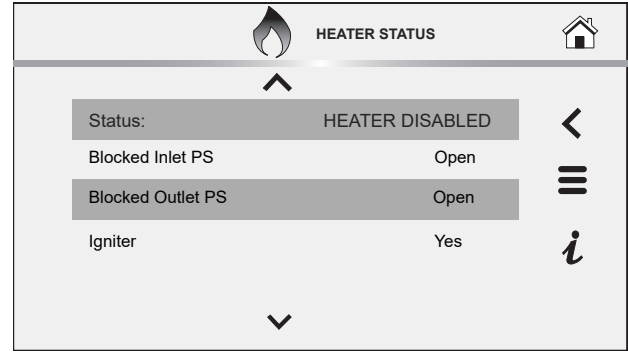

Bottom of Menu

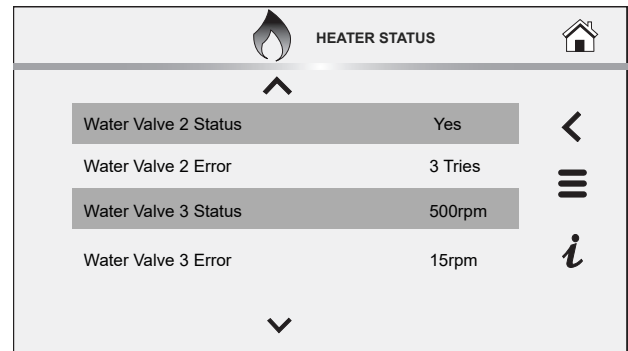

Display Settings Menu

1. From the Home screen, press MENU icon.
The “Main Menu” screen will be displayed.
2. From the Main Menu, press the Settings icon to access the Settings screen.

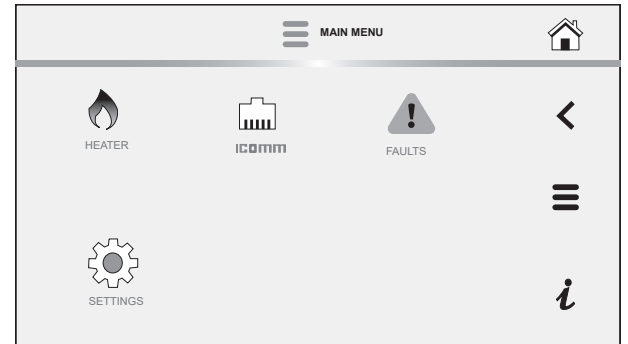

The Settings screen contains adjustable display options for viewing information on the LCD screen.

- **Temperature Units** - Adjustable user setting that changes temperature units display to Celsius °C or Fahrenheit °F.
- **Backlight Delay** - Adjustable user setting that determines how long the LCD backlight remains illuminated after a key has been pressed. Available settings are; Always Off, 10, 30 or 60 seconds and Always On.
- **Brightness** - Adjustable user setting to adjust the LCD screen contrast between text and background.
- These settings are adjusted in the same way as described **Operating Set-Point and Differential Adjustment** (page 46).
- Lock setpoint manager
- Date/Time
- Lock
- Show Contact
- Current Contact Info
- Leak Detection
- Audio Alert
- Tank Temp Probe Offset
- Use External Enable
- Disable Modulation
- Water Valve Cycle Time
- Language

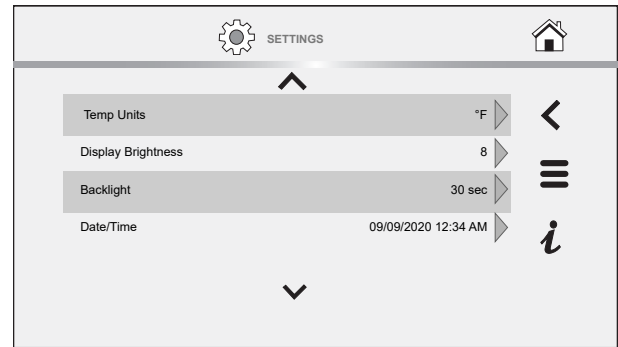

Current Fault

1. From the Home screen, press MENU icon.
The "Main Menu" screen will be displayed.
2. From the Main Menu, press the Faults icon to access the Fault Menu.

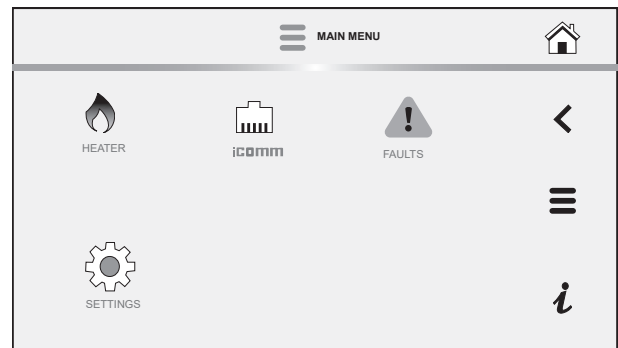

3. From the Fault Menu, press the Current Fault or Current Alert icon to access the Current Fault screen.

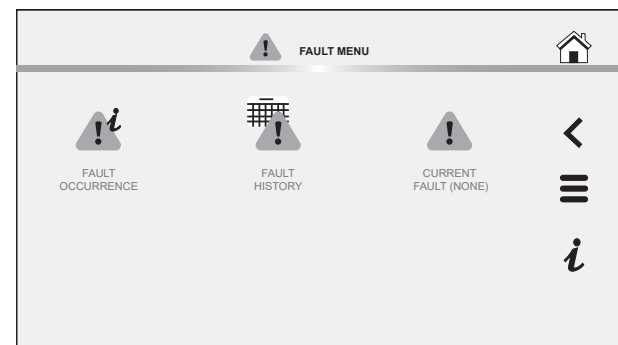

The Current Fault screen contains the current Fault or Alert error message. The time the Fault or Alert message occurred appears directly below. A brief description of what causes the particular Fault or Alert condition appears below that.

Press the MORE button for more detailed service information and a list of possible causes for the Fault or Alert condition.

See *Troubleshooting* (page 61) for more detailed information and diagnostic procedures.

If there is no Fault or Alert condition active this menu will not contain any information; “(none)” will be shown next to Current Fault in the Fault menu.

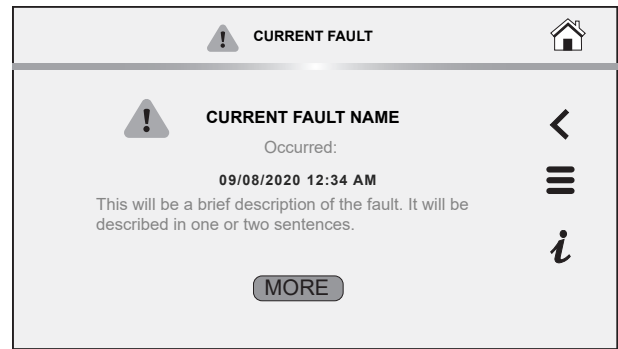

Fault History Menu

1. From the Home screen, press MENU icon.
The “Main Menu” screen will be displayed.
2. From the Main Menu, press the Faults icon to access the Fault Menu.

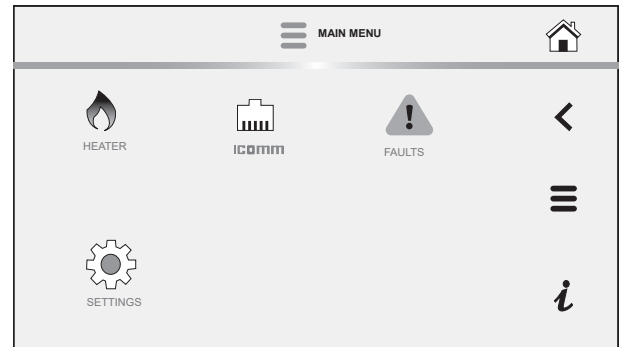

3. From the Fault Menu, press the Fault History icon to access the Fault History screen.

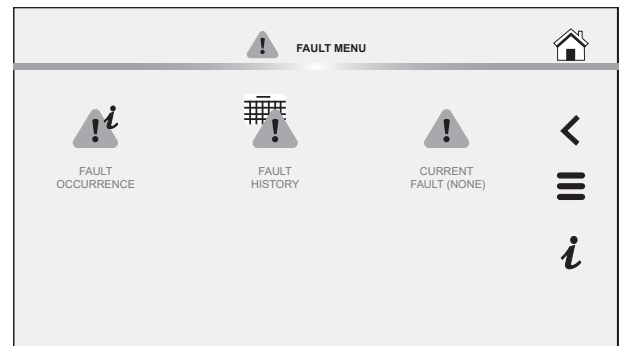

The Fault History screen contains a list of the last nine (9) Fault and Alert messages with a time stamp. The newest event will replace the oldest. Faults will clear after 30 days.

Press the Fault to view details for each Fault or Alert message stored.

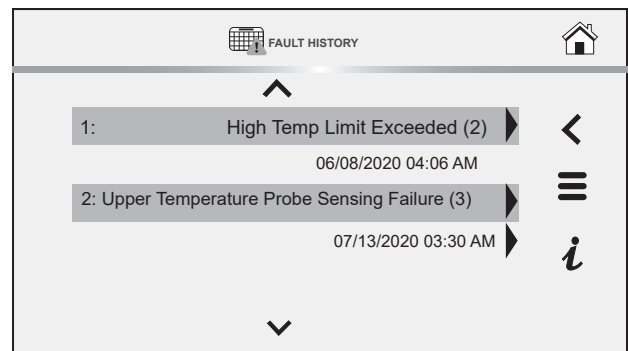

Fault Occurrence Menu

1. From the Home screen, press MENU icon.
The “Main Menu” screen will be displayed.
2. From the Main Menu, press the Faults icon to access the Fault Menu.

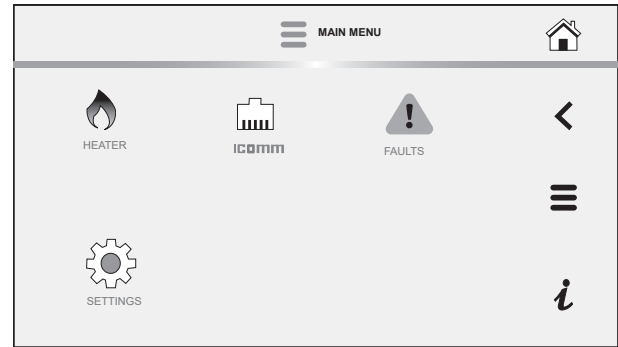

3. From the Faults Menu, press the Fault Occurrence icon to access the Fault Occurrence screen.
The Fault Occurrence screen contains a running total of how many times each Fault condition has occurred since the water heater was first installed.

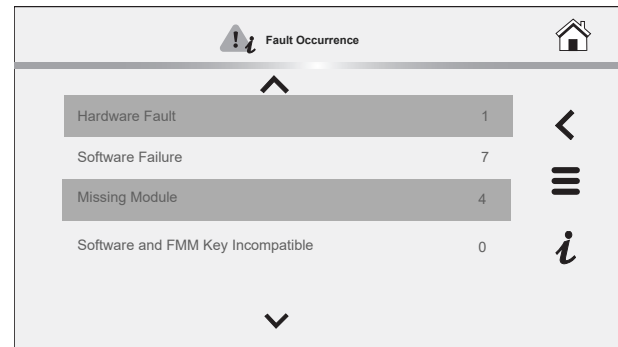

Lockout Function

1. From the Home screen, press MENU icon.
The "Main Menu" screen will be displayed.
2. From the Main Menu, press the Settings icon to access the Settings screen.
3. Use the arrow buttons to scroll through the list to the Lock item.
4. Click on the arrow to the right to access the Lock dialog box.

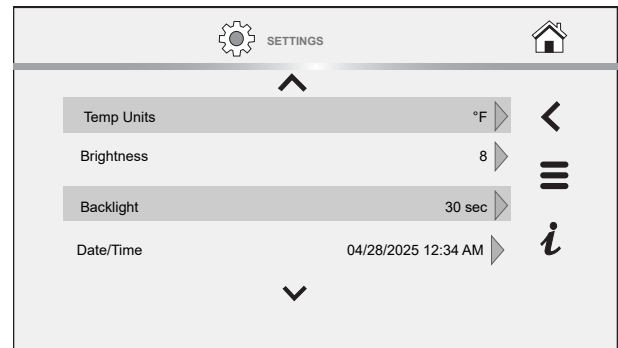
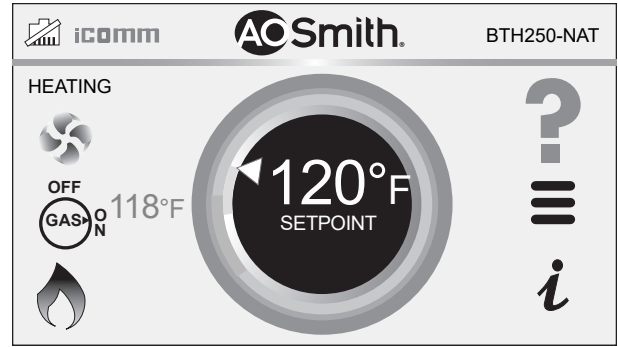

5. Use the arrows in the Lock dialog box to toggle Yes to enable the lock or No to disable the lock.
Note: The lock is disabled by default from the factory.
Click Confirm to implement your selection.

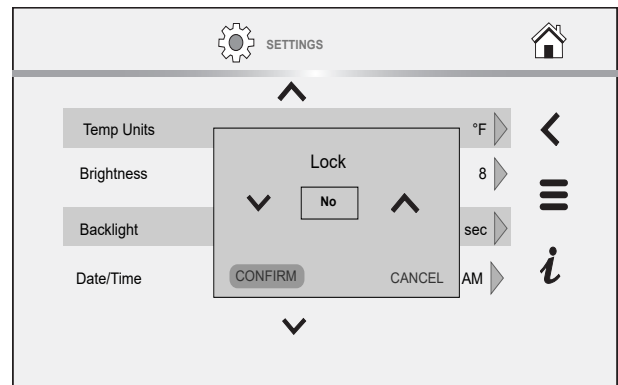

6. Press and hold on the lock icon on the Home screen to unlock the Setpoint settings

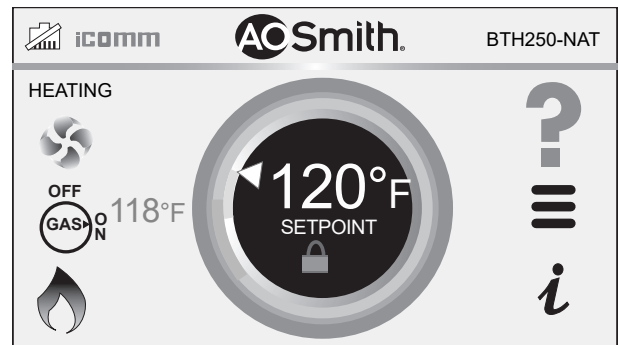

Restore Factory Defaults Function

1. Press and hold on the A. O. Smith logo on the Home screen.

The Service Information screen displays

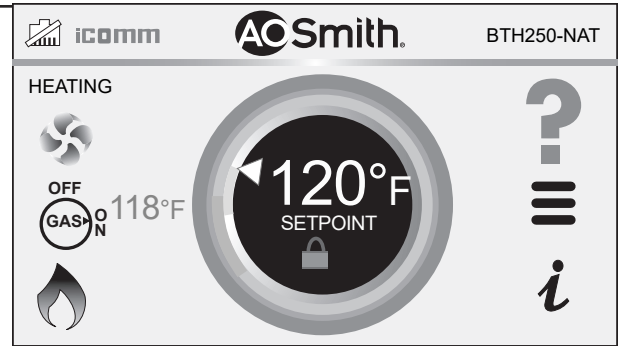

2. Select Restore User Defaults on the Service Information screen.

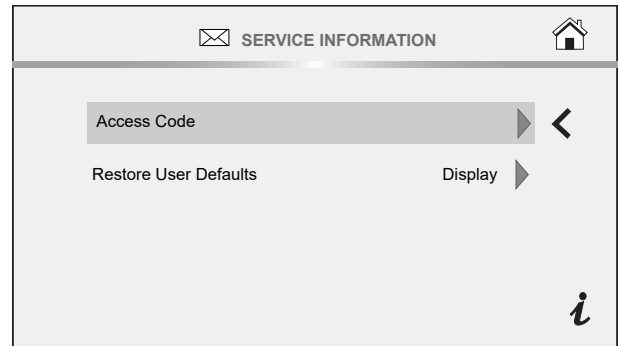

3. Ensure TRC is selected in the list menu, then press the Confirm button.

The original factory settings of the water heater are restored.

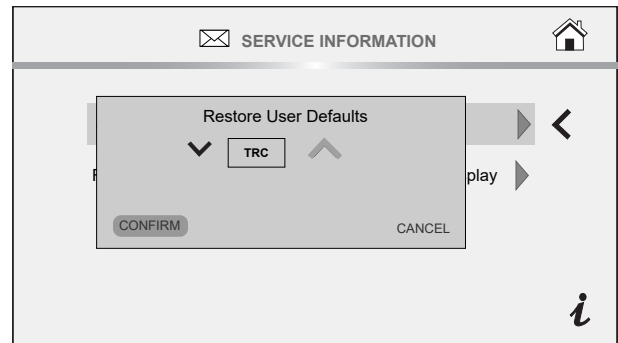

Service Contact Information

The control system has a menu that Installing contractors and/or service agents can access to enter their contact information for customers. This contact information will be displayed with all Fault and Alert messages.

1. From the Home screen, press the Main Menu icon. The Main Menu screen displays.
2. From the Main Menu screen, press the Settings icon.

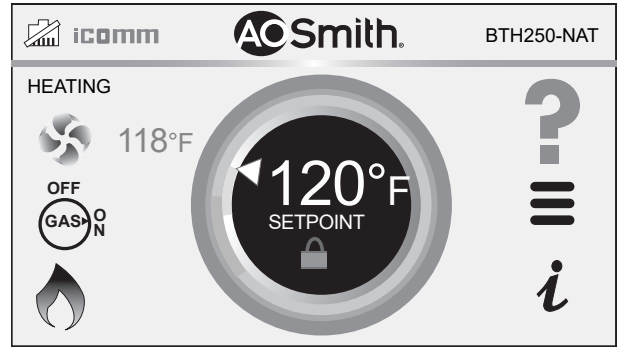

3. Scroll down to the Settings Menu and select the Current Contact Info item. The Contact Information screen displays.



4. To edit a contact information item, select it and press the Pencil icon.
5. Edit the item using the keyboard. Press the Save Key to save your data after each entry.

Note: You can enable or disable the display of Contact info by editing the "Show Contact" item on the Settings Menu.



MAINTENANCE

Table 14. Maintenance Schedule

Component	Operation	Interval	Reference
Tank	Drain and Flush	Every 6 Months	See <i>Draining and Flushing</i> .
Tank	Lime Scale Removal (Water Less Than 25 Grains Hard)	Not Required	N/A
Tank	Lime Scale Removal (Water Greater Than 25 Grains Hard)	Annually	See <i>Lime Scale Removal</i> (page 58).
Burner Flames	Inspection	Every 3 Months	See <i>Burner Inspection and Maintenance</i> (page 58).
Burner	Inspection/Cleaning	As Needed	Contact qualified agency or professional.
Moving Parts	Lubrication	Not Required	N/A
Powered Anodes	Inspection/Cleaning	Annually	See <i>Anode Rod Maintenance</i> (page 59).
T&P Valve	Test Operation	Semi Annually	See <i>Temperature-Pressure Relief Valve Test</i> (page 59).
Vent System	Inspection	Annually	See <i>Venting System Maintenance</i> .

If after inspection of the vent system you found sooting or deterioration, something is wrong. Call the local gas utility to correct the problem and clean or replace the flue and venting before resuming operation of the water heater.

DRAINING AND FLUSHING

It is recommended that the water heater storage tank be drained and flushed every 6 months to reduce sediment buildup. The water heater should be drained if being shut down during freezing temperatures. See *Figure 1* (page 10) and *Figure 2* (page 11) for the location of the water heater components described below.

⚠ DANGER

Burn Hazard

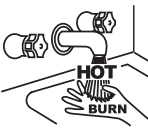

The discharge water from the drain valve is hot enough to cause burns.

Keep your hands clear of the drain valve discharge outlet.

VENTING SYSTEM MAINTENANCE

⚠ WARNING

Breathing Hazard - Carbon Monoxide Gas



- Flue gases may escape if vent pipe is not connected.
- Be alert for obstructed, sooted, or deteriorated vent system to avoid serious injury or death.
- Do not store corrosive chemicals in the vicinity of the water heater.
- Chemical corrosion of the flue and vent system can cause serious injury or death.
- Analyze the entire vent system to make sure that condensate will not become trapped in a section of vent pipe and therefore reduce the open cross sectional area of the vent.

Breathing carbon monoxide can cause brain damage or death. Always read and understand instruction manual.

Draining the Water Heater Storage Tank

- Turn off the electrical supply to the water heater.
- Turn off the gas supply at the Main Gas Shutoff Valve if the water heater is going to be shut down for an extended period.
- Ensure the cold water inlet valve is open.
- Open a nearby hot water faucet and let the water run until the water is no longer hot.
- Close the cold water inlet valve to the water heater.
- Connect a hose to the water heater drain valve and terminate it to an adequate drain.
- Open the water heater drain valve and allow all the water to drain from the storage tank.
- Close the water heater drain valve when all water in the storage tank has drained.
- Close the hot water faucet opened in Step 4.
- If the water heater is going to be shut down for an extended period, the drain valve should be left open.

Flushing the Water Heater Storage Tank

- Turn off the electrical supply to the water heater.
- Ensure the cold water inlet valve is open.
- Open a nearby hot water faucet and let the water run until the water is no longer hot. Then close the hot water faucet.
- Connect a hose to the drain valve and terminate it to an adequate drain.
- Ensure the drain hose is secured before and during the entire flushing procedure. Flushing is performed with system water pressure applied to the water heater.
- Open the water heater drain valve to flush the storage tank.
- Flush the water heater storage tank to remove sediment and allow the water to flow until it runs clean.
- Close the water heater drain valve when flushing is completed.

At least once a year examine the vent system. Points of inspection are as follows:

- Check for obstructions and/or deterioration of the intake air and/or vent piping and the intake air and vent terminations. Replace immediately where needed.
- The debris screens in the intake air and vent terminations should be cleaned of foreign material and soot.

Note: Do not reach inside the vent termination when the heater is in operation.
- Check all vent system connections for leakage and repair or reseal as necessary.

Be sure the vent piping is properly connected to prevent escape of dangerous flue gasses which could cause deadly asphyxiation.

Obstructions and deteriorated vent systems may present serious health risk or asphyxiation.

Chemical vapor corrosion of the flue and vent system may occur if air for combustion contains certain chemical vapors. Spray can propellants, cleaning solvents, refrigerator and air conditioner refrigerants, swimming pool chemicals, calcium and sodium chloride, waxes, bleach and process chemicals are typical compounds which are potentially corrosive.

9. Remove the drain hose.
10. Fill the water heater. See *Filling the Water Heater* (page 39).
11. Turn on the electrical supply to place the water heater back in operation.
12. Allow the water heater to complete several heating cycles to ensure it is operating properly.

LIME SCALE REMOVAL

When water is heated dissolved minerals in the water such as calcium and magnesium carbonate (lime scale) become less soluble. As the water temperature rises these minerals will precipitate or “fall out” of solution.

The amount of lime scale released from water is in direct proportion to water temperature and usage. The higher the water temperature or water usage, the more lime deposits are dropped out of the water.

Water hardness also affects lime scale accumulation. With the temperature and usage being the same, hard water will release more lime scale than softer water.

Lime scale reduces heating efficiency as it accumulates inside a water heater. Heating transfer surfaces become coated with lime scale deposits which increases fuel costs to operate the water heater. Lime scale deposits can also cause rumbling and pounding noises as air molecules trapped in the lime scale escape when heated. Lime scale accumulation also reduces the life span of water heaters. For these reasons a regular schedule for deliming should be set up.

Chemical Lime Scale Removal

To dissolve and remove more stubborn lime scale deposits, white vinegar should be used. Hydrochloric base acids must not be used to delime the water heaters covered in this manual.

BURNER INSPECTION AND MAINTENANCE

Flood damage to a water heater may not be readily visible or immediately detectable. However, over a period of time a flooded water heater will create dangerous conditions which can cause **DEATH, SERIOUS BODILY INJURY, OR PROPERTY DAMAGE**. Contact a qualified installer or service agency to replace a flooded water heater. Do not attempt to repair the unit! It must be replaced!

At least once a year a visual inspection should be made of the main burner and the igniter assembly for proper flame characteristics and ignition sequences. This can be done by viewing the main burner operation through the Viewport on the top cover assembly. See *Figure 1* (page 10) and *Figure 2* (page 11) for the location. The main burner should provide complete combustion of gas, ignite rapidly, give reasonably quiet operation, and cause no excessive flame lifting from the burner ports. If the proper flame characteristics are not evident, make sure that the flow of combustion and ventilation air is not blocked.

You should also check for sooting. Soot is not normal and will impair proper combustion. A visual inspection of the main burner and igniter assembly should also be done at least once a year. See *Figure 39* (page 58).

Soot build-up indicates a problem that requires correction before further use. Turn “OFF” gas to water heater and leave off until repairs are made,

because failure to correct the cause of the sooting can result in a fire causing death, serious injury, or property damage.

BURNER FLAME INSPECTION

Check main burner every three months for proper flame characteristics. You can see the burner flame through the sight glass on top of the burner plate. To access the sight glass, you must remove the plastic cover.

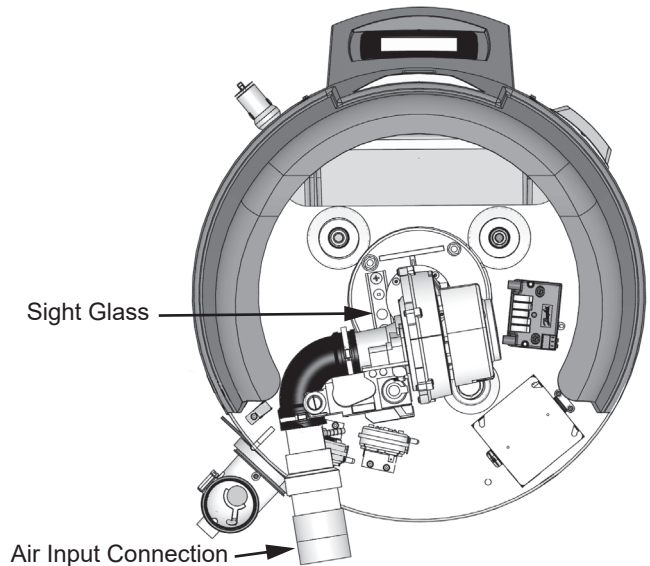

Figure 38. Location of Sight Glass - 50 Gallon

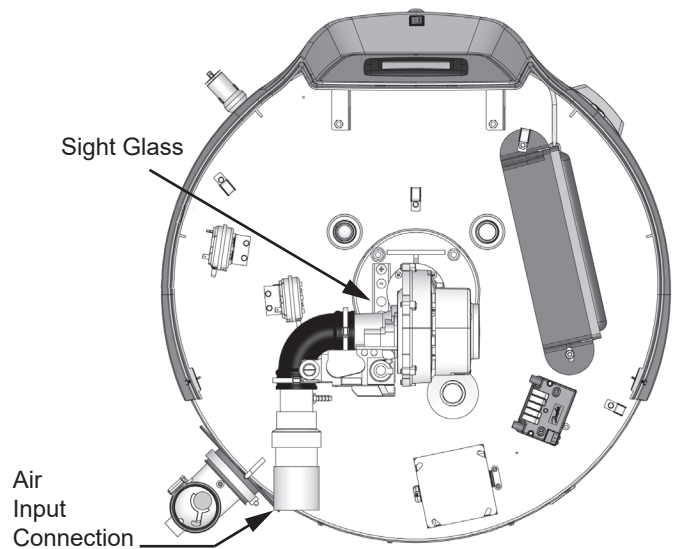

Figure 39. Location of Sight Glass - 75 Gallon

The main burner should display the following characteristics:

- Provide complete combustion of gas.
- Cause rapid ignition and carry over of flame across entire burner.
- Give reasonably quiet operation during initial ignition, operation and extinction.
- Cause no excessive lifting of flame from burner ports. See *Figure 40*.

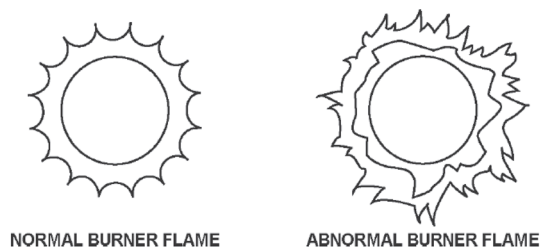



Figure 40. Normal and Abnormal Burner Flames

If the preceding burner characteristics are not evident, check for accumulation of lint or other foreign material that restricts or blocks the air intake fitting or air intake terminal.

To ensure continued good performance, keep the area around the water heater clean and free from lint and debris. Sweep the floor around the water heater regularly. This will reduce the dust and dirt which can enter the burner and heat exchanger, causing improper combustion and sooting.

If the air intake fitting and air intake terminal are clear and the burner continues to exhibit abnormal flames, contact a qualified service agency or have a qualified service professional inspect and clean the burner.

ANODE ROD MAINTENANCE

CAUTION	
Property Damage Hazard	
	<p>Operating the water heater with depleted or malfunctioning anodes can damage the water heater.</p> <p>Annual inspection and replacement of the anode rod is required.</p>

The water heaters covered in this manual are factory equipped with a powered anode rod mounted in the top of the unit. Powered anode rods are of a permanent design and do not need replacing unless damaged, however, inspection and cleaning should be performed once a year.

To inspect the powered anode, do the following:

1. Turn off electrical supply and gas supply to the water heater.
2. Shut off the water supply and open a nearby hot water faucet to depressurize the water tank.
3. Drain approximately 5 gallons of water from tank. See *Draining and Flushing* (page 57) for proper procedures. Close drain valve.
4. Remove the wiring connection on the top of the powered anode.
5. Remove the powered anode by loosening the 3/4" NPT bushing that forms the top of the anodes.
6. Remove the entire anode rod from the water heater for inspection.
 - If undamaged and in working order, clean the anode rod with a soft cloth and reinstall.
 - If the anode needs to be replaced, obtain a new anode rod. Apply Thread-sealer® tape or an approved pipe sealant on the threads before installing the new powered anode rod.

Whether re-installing or replacing the powered anode rod, check for any leaks and immediately correct if found.

7. Turn on water supply and open nearby hot water faucet to purge air from water system.
8. Refill the water heater following the instructions for *Filling the Water Heater* (page 39).
9. Restart the water heater as directed in this manual.

TEMPERATURE-PRESSURE RELIEF VALVE TEST

⚠ DANGER	
Burn Hazard	
	<p>The discharge water from the temperature-pressure relief valve is hot enough to cause burns.</p> <p>Keep clear of the temperature-pressure relief valve discharge outlet.</p>

It is recommended that the Temperature-Pressure Relief Valve should be checked to ensure that it is in operating condition every 6 months.

When checking the Temperature-Pressure Relief Valve operation, make sure that (1) no one is in front of or around the outlet of the Temperature-Pressure Relief Valve discharge line, and (2) that the water discharge will not cause any property damage, as water may be extremely hot. Use care when operating valve as the valve may be hot.

To check the temperature-pressure relief valve, lift the lever at the end of the valve several times. See *Figure 41*. The valve should seat properly and operate freely.

If after manually operating the valve, it fails to completely reset and continues to release water, immediately close the cold water inlet to the water heater and drain the water heater. See *Draining and Flushing* (page 57). Replace the Temperature-Pressure Relief Valve with a properly rated/sized new one. See *Temperature-Pressure Relief Valve* (page 23) for instructions on replacement.

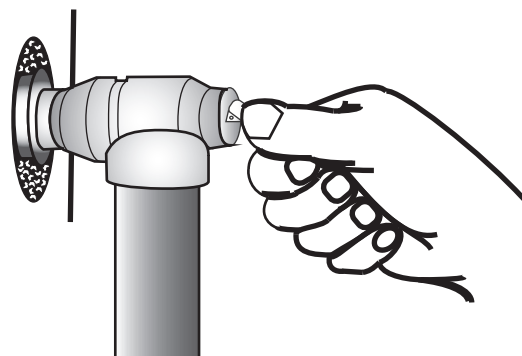

Figure 41. Testing the Temperature-Pressure Relief Valve

If the Temperature-Pressure Relief Valve on the water heater weeps or discharges periodically, this may be due to thermal expansion.

Note: Excessive water pressure is the most common cause of Temperature-Pressure Relief Valve leakage. Excessive water system pressure is most often caused by "thermal expansion" in a "closed system." See *Closed Water Systems* (page 22) and *Thermal Expansion* (page 22). The Temperature-Pressure Relief Valve is not intended for the constant relief of thermal expansion.

Temperature-Pressure Relief Valve leakage due to pressure build up in a closed system that does not have a thermal expansion tank installed is

not covered under the limited warranty. Thermal expansion tanks must be installed on all closed water systems.

Do not plug the Temperature-Pressure Relief Valve opening. This can cause property damage, serious injury or death.

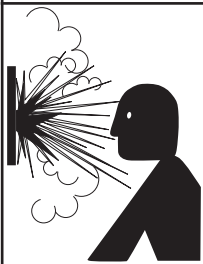
⚠ WARNING	
Explosion Hazard	
	<p>Normal operation of the water heater can cause it to become sufficiently over-heated and/or over-pressurized that it can explode, resulting in property damage, sever injury, or death.</p> <p>To avoid this hazard, you must install a properly-sized temperature-pressure relief valve in opening provided.</p> <ul style="list-style-type: none">• The temperature-pressure relief valve must comply with ANSI Z21.22-CSA 4.4 and ASME code.• Do not plug, block, or cap the discharge line.

SERVICE

If a condition persists or you are uncertain about the operation of the water heater contact a qualified service technician.

Use this guide to check a leaking water heater. Many suspected leaks are not leaking tanks. Often the source of the water can be found and corrected.

If you are not thoroughly familiar with gas codes, your water heater, and safety practices, contact your gas supplier or qualified installer to check the water heater.

Read this manual first. Then before checking the water heater make sure the gas supply has been turned "OFF", and never turn the gas "ON" before the tank is completely full of water.

TROUBLESHOOTING

INSTALLATION CHECKLIST

The list below represents some of the most critical installation requirements that, when overlooked, often result in operational problems, down time and needless parts replacement. This is not a complete list. Before performing any troubleshooting procedures use the list below to check for installation errors. Costs to correct installation errors are not covered under the limited warranty. Ensure all installation requirements and instructions in this manual have been maintained and followed.

Water Heater Location

1. Ensure proper clearances to combustibles are maintained and there is sufficient room to service the water heater.
2. Ensure the area is free of corrosive elements and flammable materials.

Venting

3. Ensure the intake air and/or vent (exhaust) piping is the correct size for the installed length.
4. Ensure the maximum equivalent length of pipe has not been exceeded for the intake air and/or vent pipe.
5. Ensure the maximum number of elbows has not been exceeded in the intake air and/or vent pipe.
6. Ensure all exterior clearances for the intake air, vent and concentric terminations are maintained. These clearances and those cited by local and national codes must be maintained.
7. If venting direct vent, ensure the screen located in air intake at the water heater was removed.

Gas Supply And Piping

8. Ensure the supply gas line to each water heater meets the minimum supply gas line size requirements.

Condensate Drain

9. Ensure the condensate drain is properly connected to the exhaust elbow on the water heater and draining freely to a suitable floor drain.

Electrical Connections

10. Ensure the water heater is properly grounded. Flame sensing requires an adequate earth ground. If the water heater is not properly grounded it will cause Ignition Failure.
11. Ensure the power supply connections to the water heater are polarity correct.

SEQUENCE OF OPERATION

Read the Sequence of Operation section before attempting to correct any operational problems. See *Features and Components* (page 10) for the location of various water heater components described in this section.

1. When the control system is powered (after initial calibration sequence), during boot up, it will display water heater model information during initialization. After a few moments the control system LCD Touch Display which is part of the UIM (user interface module) will display the default screen known as the "Home" screen.
2. If the control system determines that the actual water temperature inside the tank is below the programmed Operating Set Point minus the Differential setting, a heating cycle is activated.
3. The control system then performs selected diagnostic system checks. This includes confirming the blocked exhaust, blocked intake and high-temperature limit control (energy cut out) are not activated.
4. If all diagnostic checks are successfully passed, the control system energizes the Combustion Blower for prepurge.
5. The control system energizes the Spark Ignition Transformer..
6. After a few seconds, the control system energizes the Gas Control Valve allowing gas to flow to the Main Burner.
7. The control system monitors the flame sensor to confirm a flame is present at the Main Burner. If a flame is not verified during the ignition trial period the control system will try for ignition up to two more times. If flame can not be verified after three trials for ignition, the control system will lock out and display the "Ignition Failure" Fault message.
8. If a flame is verified, the control system will deenergize the Spark Ignition Transformer and enter the heating mode where it will continue heating the water until the Operating Set Point is reached. At this point, the control system will deenergize the gas valve and enter the post-purge cycle.
9. The Combustion Blower will run for the duration of the post purge cycle to purge the water heater of all combustion gases. When the post-purge cycle is complete, the blower is deenergized and will coast to a stop.
10. The control system now enters the standby mode while continuing to monitor the internal storage tank water temperature and the state of other system devices. If the tank temperature drops below the Operating Set Point minus the Differential setting, the control will automatically return to Step 2 and repeat the operating cycle.

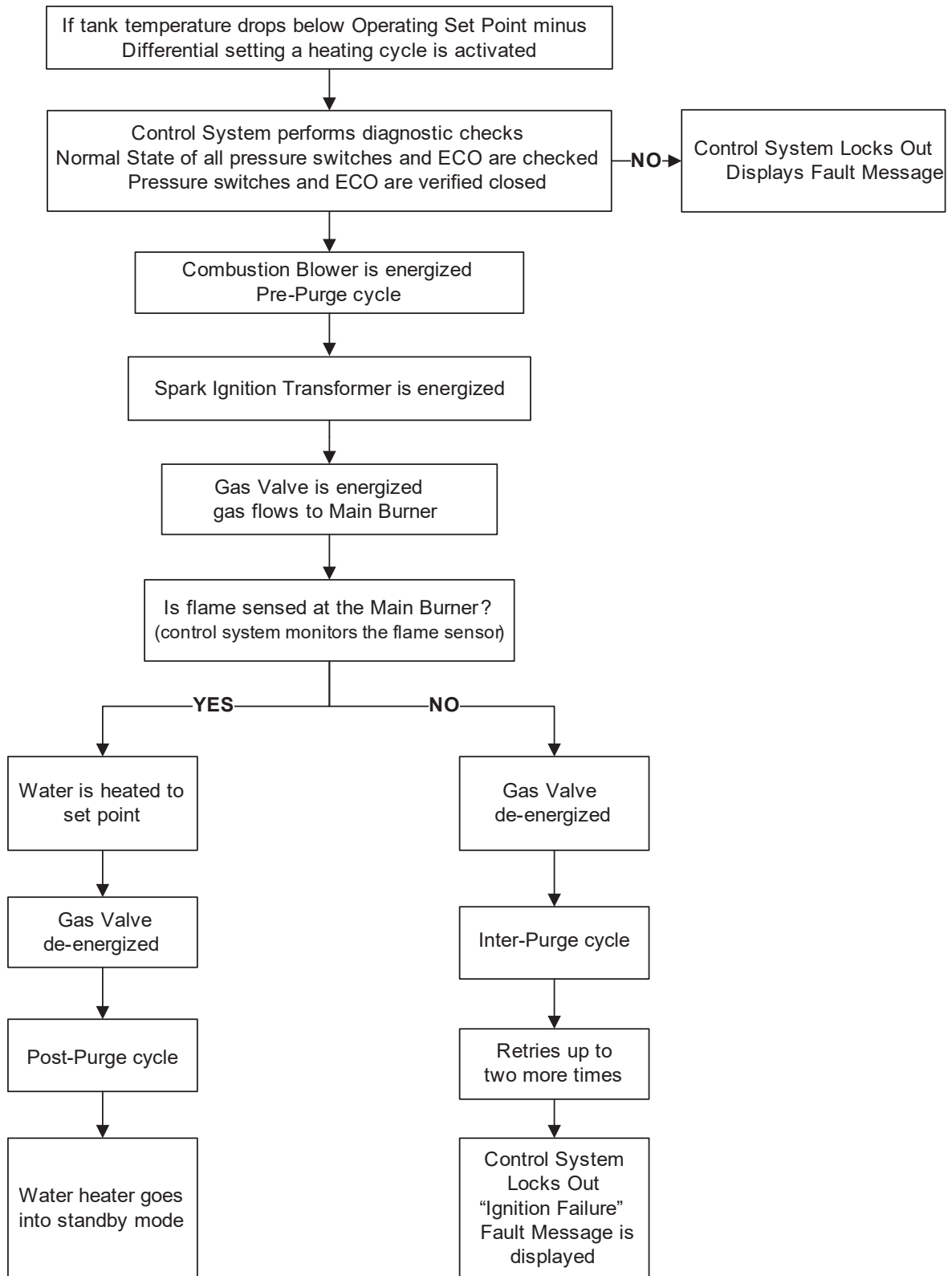



Figure 42. Sequence of Operation

START UP CONDITIONS

Smoke/Odor

It is not uncommon to experience a small amount of smoke and odor during the initial start-up. This is due to burning off of oil from metal parts, and will disappear in a short while.

Thermal Expansion

CAUTION	
Property Damage Hazard	
	<p>Avoid water heater damage from pressure fluctuations in closed water systems.</p> <ul style="list-style-type: none"> • Fill tank with water before operating. • Install thermal expansion tank if necessary. • Do not apply heat to cold water inlet. • Contact qualified installer or service agency.

Water supply systems may, because of such events as high line pressure, frequent cut-offs, the effects of water hammer among others, have installed devices such as pressure reducing valves, check valves, back flow preventers, etc. to control these types of problems. When these devices are not equipped with an internal by pass, and no other measures are taken, the devices cause the water system to be closed. As water is heated, it expands (thermal expansion) and closed systems do not allow for the expansion of heated water.

The water within the water tank expands as it is heated and increases the pressure of the water system. If the relieving point of the water heater's temperature-pressure relief valve is reached, the valve will release excess pressure. The temperature-pressure relief valve is not intended for the constant relief of thermal expansion. This is an unacceptable condition and must be corrected. It is recommended that any devices installed which could create a closed system have a by-pass and/or the system have an expansion tank or device to relieve the pressure built by thermal expansion in the water system. Expansion tanks are available for ordering through a local plumbing contractor. Contact the local water heater supplier or qualified service agency for assistance in controlling these situations.

OPERATIONAL CONDITIONS

Do not remove the powered anode rod leaving the tank unprotected. By doing so, all warranty on the water heater tank is voided.

Air In Hot Water Faucets

WARNING	
Explosion Hazard	
	<p>Flammable hydrogen gases can form in water pipes. The hydrogen can explode if it is exposed to flame and can cause severe injury or death.</p> <p>Keep all ignition sources away from faucet when turning on hot water.</p>

HYDROGEN GAS: Hydrogen gas can be produced in a hot water system that has not been used for a long period of time (generally two weeks or more). Hydrogen gas is extremely flammable and explosive. To prevent the possibility of injury under these conditions, we recommend the hot water faucet, located farthest away, be opened for several minutes before any electrical appliances which are connected to the hot water system are used (such as a dishwasher or washing machine). If hydrogen gas is present, there will probably be an unusual sound similar to air escaping through the pipe as the hot water faucet is opened. There must be no smoking or open flame near the faucet at the time it is open.

OPERATIONAL PROBLEMS

WARNING	
Safety Hazard	
	<p>Failure to follow these instructions and safety messages could result in death or serious injury.</p> <p>Read and understand this instruction manual and the safety messages herein before installing, operating or servicing this water heater.</p> <p>This manual must remain with the water heater.</p>

This section of the manual is intended to be an aid in correcting common operational problems, it is not all inclusive. The installer may be able to observe and correct certain problems which might arise when the water heater is first put into operation or when it is re-fired after a prolonged shutdown. However, only qualified service technician should perform any service procedures on the water heater.

Note: For technical support or to locate a qualified service technician in your area, call the phone number on the warranty sheet supplied with this water heater.

Rough Starting, Rough Operation

WARNING	
Fire and Explosion Hazard	
	<p>An improper field conversion from one type of gas to another could cause potentially dangerous conditions that may cause an explosion or fire resulting in property damage, bodily injury or death.</p> <p>Do not attempt to convert a water heater without consulting A. O. Smith.</p>

- Undersized supply gas line (low volume of supply gas).
- Low Gas Pressure.
- Excessive supply gas pressure.
- Excessive manifold (offset) gas pressure.
- Incorrect Fuel Type
- Vent (exhaust) gas recirculation at the vent and intake air pipe terminations on Direct Vent installations.
- Excessive equivalent lengths of intake air and/or vent (exhaust) piping installed.
- Clogged/blocked intake air screen(s).
- Clogged/blocked the Main Burner.

Momentary Ignition

CAUTION	
Burn Hazard	
	<ul style="list-style-type: none"> • The combustion chamber and burner sleeve and housing become very hot during operation. • Do not reach into the burner housing or combustion chamber if the water heater is still hot. • Allow the water heater to cool and always use gloves when handling the main burner.

If the Main Burner ignites momentarily but does not sustain ignition, the water heater will try to ignite up to two more times until control system locks out and the Ignition Failure Fault message is displayed on the control system's LCD. If the water heater is experiencing rough starts. See **Rough Starting, Rough Operation** on this page. For momentary ignition problems without rough starting check the following:

- Incorrect manifold (offset) gas pressure.
- Undersized supply gas line (low volume of supply gas).
- Low Gas Pressure
- See the list of possible causes and things to check and repair for the Ignition Failure Fault message.
- Clogged/blocked intake air screen(s).
- Clogged/blocked Main Burner.

Not Enough Or No Hot Water

- No power to the water heater, check breaker, fuses.
- Enable/Disable switch in “disabled” position. Set to enable to allow unit to operate.
- Hot water supply valve(s) to fixtures closed.
- Operating Set Point is set too low, Differential setting is set too high.
- The heating capacity of the water heater has been exceeded, the water heater is unable to meet demand.
- Colder incoming water temperature lengthening the time required to heat water to desired temperature.
- Hot water piping leaks, open faucets, water heater drain valve leaking or open.
- Sediment or lime scale accumulation may be affecting water heater operation.

Water Is Too Hot

- Operating Set Point is set too high.
- If installed check thermostatic point-of-use mixing valve settings.
- Lime build-up on temperature probe. Inspect and clean.

Noisy Operation

- Normal operating noise of electrical components; Combustion Blower, transformer hum, relay contact closure, or incorrect venting configuration

REPLACEMENT PARTS

Replacement parts may be ordered from the manufacturer, authorized service agencies or distributors. When ordering parts be sure to have the complete water heater Model Number, Serial Number and Series Number available. This information can be found on the rating plate affixed to the water heater.

For more information or technical support call the phone number on the warranty sheet supplied with this water heater.

WARNING	
Electrical Shock Hazard	
	<p>Servicing this water heater exposes you to electrified components that can cause severe injury or death if you touch them.</p> <ul style="list-style-type: none"> • Turn off power at the branch circuit breaker serving the water heater before performing any service. • Label all wires prior to disconnecting when performing service. Wiring errors can cause improper and dangerous operation. • Verify proper operation after servicing.

FAULT AND ALERT CONDITIONS

Fault Conditions

When the control system declares a Fault condition it will display a Fault message on the control system's LCD with an exclamation "!" mark. For soft faults, the system will try to reset in 15 minutes or the system can reset the heater enable switch immediately. The water heater must be serviced by a qualified service technician before operation can be restored for some fault conditions.

Alert Conditions

When the control system declares an Alert condition it will display an Alert message on the control system's LCD with a question "?" mark. The water heater will continue to operate during an Alert condition but the water heater must be serviced by a qualified service technician as soon as possible.

Resetting Control System Lock Outs

To reset the control system from a lock out condition, turn off the switch in front of the unit for approximately 20 seconds and then back on. Keep in mind that if the condition that caused the Fault has not been corrected, the control system will continue to lock out.

Diagnostic Checks

The following section, Fault And Alert Messages lists some of the messages the control system will display on the LCD when there are operational problems. This is not a complete list. Along with each of the Fault and Alert messages described there will be a list of possible causes and things to check and repair. In addition, each fault/alert code has advanced text to further detail the issue. This can be accessed by tapping the “More” button on the fault/alert screen.

Only qualified service technician, as defined in Qualifications using appropriate test equipment, should perform any service procedures on the water heater.

Note: If you are not qualified and licensed or certified as required by the authority having jurisdiction to perform a given task do not attempt to perform any of the diagnostic or service procedures described in the following section.

If you do not understand the instructions in the following section do not attempt to perform any procedures.

Call the technical support phone number listed on the water heater labeling for further technical assistance or to locate a qualified service technician in your area.

WARNING	
Safety Hazard	
	<p>Jumping out control circuits or components can result in property damage, personal injury or death.</p> <ul style="list-style-type: none"> • Service should only be performed by a qualified service technician using proper test equipment. • Altering the water heater controls and/or wiring in any way could result in permanent damage to the controls or water heater and is not covered under the limited warranty. • Any bypass or alteration of the water heater controls and/or wiring will result in voiding the appliance warranty.

Fault and Alert Messages

Contact Technical Support for further assistance or to locate a qualified service agent in your area. See the contact-information label on the water heater.

Fault and Alert Messages		
FAULT CODE	Possible Causes - Check/Repair	Displayed Fault/Alert Message
<p>2</p> <p>Data Error Code: (3, 30) NTC A short (3, 31) NTC A open (3, 32) NTC B short (3, 33) NTC B open (3,1001) NTC C open (3,1002) NTC C short (3,1018) NTC drift</p>	<p>High Temp Limit Exceeded</p> <p>The water heater is shut down due to high tank temperature.</p> <p>The water temperature in the tank has exceeded the high temperature limit.</p> <ol style="list-style-type: none"> 1. Use a thermometer at a hot water fixture to confirm the actual water temperature. If temperature is below 180° reset water heater. 2. If problem continues, contact technical support or refer to the service handbook for further instructions. 	
<p>3</p> <p>Data Error Code: 30;31; 32;33</p>	<p>Main Temperature Probe Failure</p> <p>The indicated temperature probe might be shorted or open.</p> <p>The control system has detected an issue with the main temperature probe.</p> <ol style="list-style-type: none"> 1. Ensure the wire connections for the main temp probe are clean and secure. 2. Ensure the wire harness for the main temp probe is free from damages. 3. If the problem continues, contact technical support or refer to the service handbook for further instructions. <p>Note: If there are both main and lower temperature probes, the Main Temperature probe is the main temperature probe.</p>	
<p>5</p> <p>Data Error Code: (3,10xx) where xx = 5,9,13 or 17</p>	<p>Software Failure</p> <p>Internal control failures are detected on TRC. Cycle power to the water heater.</p> <p>The controls system has detected a software issue.</p> <ol style="list-style-type: none"> 1. Cycle the main power supply to the water heater by turning off the breaker/disconnect, then wait approximately 30 seconds and turn main power supply back on. 2. If problem continues, contact Technical Support or refer to the service handbook for further instructions. 	

Fault and Alert Messages		
FAULT CODE	Possible Causes - Check/Repair	Displayed Fault/Alert Message
<p>6</p> <p>(6,10xx) where xx = 4, 8, 12 or 16</p> <p>OR</p> <p>(6,80xx) where xx = 1-10</p>	<p>Hardware Failure</p> <p>Internal control failures are detected on the TRC. Cycle power to the water heater.</p> <p>The controls system has detected a hardware issue.</p> <ol style="list-style-type: none"> 1. Cycle the main power supply to the water heater by turning off the breaker/disconnect, then wait approximately 30 seconds and turn main power supply back on. 2. If problem continues, contact Technical Support or refer to the service handbook for further instructions. 	
<p>9</p> <p>Data Error Code: 22</p>	<p>Power Supply Fault</p> <p>The Control System is detecting a problem with the incoming power supply.</p> <ol style="list-style-type: none"> 1. Cycle the main power supply to the heater by turning off the breaker/disconnect, then wait approximately 30 seconds and turn main power supply back on. 2. If problem continues, contact technical support or refer to the service handbook for further instructions. 	
<p>20</p> <p>Data Error Code: (20,0)</p>	<p>Communication Failure</p> <p>Communications between the display and the TRC is lost.</p> <p>The control system has lost communications with UIM.</p> <ol style="list-style-type: none"> 1. Cycle the main power supply to the heater by turning off the breaker/disconnect, then wait approximately 30 seconds and turn main power supply back on. 2. Inspect the communication cable between the UIM and the TRC to ensure the cable is not damaged and the connections are clean and secure. 3. If problem continues, contact technical support, or refer to the service handbook for further instructions. 	
<p>25</p> <p>Data Error Code: (4,1010) NTC open (4,1011) NTC short</p>	<p>Flue Gas Temperature Probe Failure</p> <p>The flue gas temperature probe might be shorted or open.</p> <p>The control system has detected an issue with the flue gas temperature probe.</p> <ol style="list-style-type: none"> 1. Cycle the main power supply to the heater by turning off the breaker/disconnect, then wait approximately 30 seconds and turn main power supply back on. 2. If problem continues, contact technical support for further instructions. 	

Fault and Alert Messages		
FAULT CODE	Possible Causes - Check/Repair	Displayed Fault/Alert Message
<p>31</p> <p>Data Error Code: (31,7002) or (31, 7003) or (31, 7004)</p>	<p>Water Leak Detected</p> <p>A water leak or other water-present condition is being detected. Check for a leak or other water problem at the water sensor.</p> <p>The control system has detected a leak near the heater.</p> <ol style="list-style-type: none"> 1. Inspect the area around the heater for signs of moisture. 2. Inspect all threaded fittings connected to the water heater for signs of moisture. 3. Inspect the exhaust elbow connection to the heater for signs of moisture. 4. Inspect the clean-out cover for signs of moisture. 5. Using litmus strips for pH testing to identify if the moisture is condensate or water from the tank. 6. Condensation from the exhaust will be highly acidic. 7. If problem continues, contact technical support for further instructions. 	
<p>32</p> <p>Data Error Code: (32, 7001)</p>	<p>Leak Sensor Disconnected</p> <p>The leak sensor is no longer being detected by the controller.</p> <p>The control system has detected that the leak detector has been disconnected.</p> <ol style="list-style-type: none"> 1. Ensure the leak detector is securely connected to the water heater. 2. Ensure the leak detector harness is securely connected to the TRC at terminal J6 pins 1 and 11. 3. If problem continues, contact technical support for further instructions. 	
<p>33</p> <p>Data Error Code: (33, 60x7) where x = 0 is on TRC-1000 board anode circuit. x = 1 is CPAM 1, x = 2 is CPAM 2 etc.</p>	<p>Anode Shorted</p> <p>The powered anode is shorted to earth ground or to the tank.</p> <p>The Control System has detected that the anode rod has shortage to the tank.</p> <ol style="list-style-type: none"> 1. Inspect anode wire connection for corrosion, moisture, or other contaminates. 2. Ensure wire connection on both ends is secure. 3. Ensure anode wire harness is not damaged. 4. If problem continues, contact technical support for further instructions. 	

Fault and Alert Messages		
FAULT CODE	Possible Causes - Check/Repair	Displayed Fault/Alert Message
<p>34</p> <p>Data Error Code: (34, 60x4) where x = 0 is on TRC-1000 board anode circuit. x = 1 is CPAM 1, x = 2 is CPAM 2 etc.</p>	<p>No Water</p> <p>No water is detected by the powered anode.</p> <p>The Control System is not detecting water in the tank.</p> <ol style="list-style-type: none"> 1. Ensure there is water in the tank by following Fill the Tank Instructions found in the installation manual. 2. Inspect anode wire connection for corrosion, moisture, or other contaminants. 3. Ensure wire connection on both ends is secure. 4. Ensure anode wire harness is not damaged. 5. If problem continues, contact technical support for further instructions. 	
<p>36</p> <p>Data Error Code: 244 (36, 2440x) where x = 1 to 9 are reason codes.</p>	<p>Weak Flame Signal</p> <p>The Combustion Safety Control (CSC) is detecting low-flame generated current.</p> <p>The control system has detected a weak flame signal</p> <ol style="list-style-type: none"> 1. Ensure that the flame sensor wire harness is free of damages 2. Ensure that the flame sensor wire connection on both ends is secure and free of contaminants 3. Remove flame sensor and inspect for contaminants or damages in ceramic insulator 4. Clean flame sensor rod with steel wool 5. If the problem continues, contact technical support, or refer to the service handbook for further instructions 	
<p>37</p> <p>Data Error Code: 2, 130 (37, 2) Or (37, 130)</p>	<p>Flame Sensor Error</p> <p>The control system has detected a flame sensor error.</p> <p>The flame-sense rod is detecting a flame signal when the gas valve is supposed to be off.</p> <p>The control system has detected a flame sensor error.</p> <ol style="list-style-type: none"> 1. Ensure that the flame sensor wire harness is free of damages. 2. Ensure that the flame sensor wire connection on both ends is secure and free of contaminants. 3. Remove flame sensor and inspect for contaminants or damages in ceramic insulator. 4. Clean flame sensor rod with steel wool. 5. If the problem continues, contact technical support, or refer to the service handbook for further instructions. 	

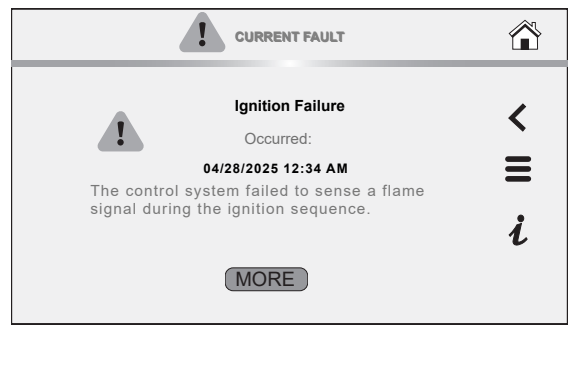
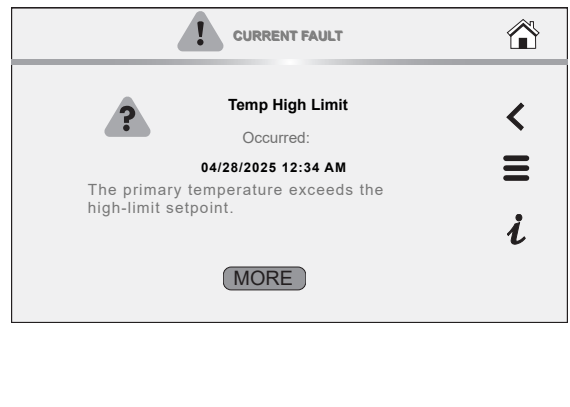
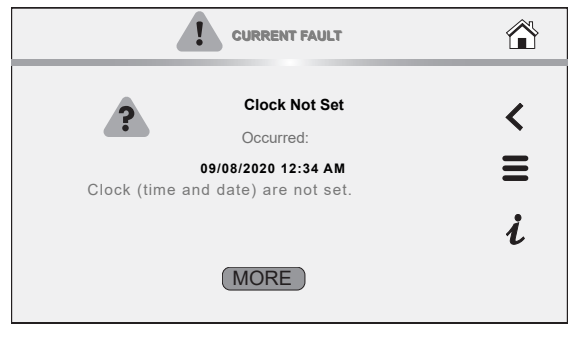
Fault and Alert Messages		
FAULT CODE	Possible Causes - Check/Repair	Displayed Fault/Alert Message
<p>38 (Resideo 129, 147, 241) or 38</p> <p>Data Error Code: (38, 129) or (38, 147) or (38, 241) or (38, 38)</p>	<p>Ignition Failure</p> <p>The control system failed to sense a flame signal during the ignition sequence.</p> <p>The control system failed to sense a flame signal during the ignition sequence</p> <ol style="list-style-type: none"> 1. Verify that the gas supply, venting, and intake air pipes are installed according to the instruction manual provided with the water heater. 2. If the problem continues, contact technical support, or refer to the service handbook for further instructions. 	 <p>The screenshot shows a 'CURRENT FAULT' alert titled 'Ignition Failure'. It includes a warning icon, the text 'Occurred: 04/28/2025 12:34 AM', and the description 'The control system failed to sense a flame signal during the ignition sequence.' There are navigation icons for back, menu, and info, and a 'MORE' button.</p>
<p>41</p> <p>Data Error Code: (41, 1003)</p>	<p>High Temperature Warning</p> <p>The main temperature probe exceeds 190°F.</p> <p>The water temperature in the tank has exceeded the high temperature warning temperature. The warning will reset when tank temperature drops below 180°F.</p> <ol style="list-style-type: none"> 1. Reset the water heater by toggling the Enable/Disable switch to disable and back to enable. 2. If the problem continues, use a thermometer at a hot water fixture to confirm the water temperature. 3. If the problem continues, contact technical support or refer to the service handbook for further instructions. 	 <p>The screenshot shows a 'CURRENT FAULT' alert titled 'Temp High Limit'. It includes a warning icon with a question mark, the text 'Occurred: 04/28/2025 12:34 AM', and the description 'The primary temperature exceeds the high-limit setpoint.' There are navigation icons for back, menu, and info, and a 'MORE' button.</p>
<p>42</p>	<p>Clock Not Set</p> <p>Clock (time and date) are not set.</p> <p>Check the iComm connection (if equipped) and reconnect for automatic calendar updates.</p> <p>The control system recognized that the clock is not set.</p> <ol style="list-style-type: none"> 1. Refer to the installation manual for instructions on how to set the clock. 2. If the problem continues, contact technical support for further instructions. 	 <p>The screenshot shows a 'CURRENT FAULT' alert titled 'Clock Not Set'. It includes a warning icon with a question mark, the text 'Occurred: 09/08/2020 12:34 AM', and the description 'Clock (time and date) are not set.' There are navigation icons for back, menu, and info, and a 'MORE' button.</p>

Fault and Alert Messages		
FAULT CODE	Possible Causes - Check/Repair	Displayed Fault/Alert Message
<p>201</p> <p>Data Error Code: 71 (201, 71)</p>	<p>Blocked Air Intake</p> <p>There is a restriction in the air intake. Check the intake pipe and termination for blockage.</p> <p>The control system has detected a blockage in the intake air pipe.</p> <ol style="list-style-type: none"> 1. Ensure that the intake air pipe installed according to the manufacturer’s installation manual. 2. Ensure that all horizontal pipe runs are properly sloped to prevent moisture from accumulating and restricting air flow. 3. Inspect the inside of the intake air pipe from the connection at the blower, all the way to the outside termination for restrictions. 4. Inspect the plastic sensing tube to the blocked intake air pressure switch to ensure there are no restrictions. 5. Ensure the blocked intake air pressure switch wires are free from damages and contaminates. 6. Ensure wire connections are secure and free from contaminates. 7. If problem continues, contact technical support, or refer to the service handbook for further instructions. 	
<p>202</p> <p>Data Error Code: 70 (202, 70)</p>	<p>Blocked Exhaust</p> <p>There is a restriction in exhaust pipe. Check exhaust pipe and termination for blockage.</p> <p>The control system has detected a blockage in the exhaust vent pipe.</p> <ol style="list-style-type: none"> 1. Ensure that the exhaust vent pipe installed according to the manufacturer’s installation manual. 2. Ensure that all horizontal pipe runs are properly sloped to prevent moisture from accumulating and restricting air flow. 3. Inspect the inside of the exhaust vent pipe from the water heater connection all the way to the outside termination for restrictions. 4. Inspect the plastic sensing tube to the blocked exhaust pressure switch to ensure there are no restrictions. 5. Ensure the blocked exhaust pressure switch wires are free from damages and contaminates. 6. Ensure wire connections are secure and free from contaminates. 7. If problem continues, contact technical support, or refer to the service handbook for further instructions. 	
<p>205</p> <p>Data Error Code: (205,200x)</p> <p>Where: x=2 if the key is uninitialized x=3 if key configuration is corrupt.</p>	<p>Software and FMM Incompatible</p> <p>The TRC version is older than the TRC version stored in key.</p> <p>The control system has detected a device that is incompatible</p> <ol style="list-style-type: none"> 1. Contact Technical Support for further instructions. 	

Fault and Alert Messages		
FAULT CODE	Possible Causes - Check/Repair	Displayed Fault/Alert Message
<p>206</p> <p>Data Error Code: (206, 2011)</p>	<p>CPAM Disconnected</p> <p>Communication with the anode module has been lost.</p> <p>The control system has detected that the CPAM is disconnected</p> <ol style="list-style-type: none"> 1. Ensure CPAM is powered 2. Ensure wire connections are secure and free of contaminates 3. Ensure wire harness is free of damages 4. If problem continues, contact technical support or refer to the service handbook for further instructions 	
<p>207</p> <p>Data Error Code: (207, 35)</p>	<p>CSC Disconnected</p> <p>Communication with the Combustion Safety control (CSC) has been lost.</p> <p>The CSC is disconnected</p> <ol style="list-style-type: none"> 1. Ensure the communication cable is securely connected between the TRC on terminal J4 and the CSC on terminal X10. 2. If problem continues, contact technical support or refer to the service handbook for further instructions. 	
<p>209</p> <p>Data Error Code: (209, 2013)</p>	<p>Water Valve Module Disconnected</p> <p>Communication with the water valve module has been lost.</p> <p>The control system has detected that the Valve Module is disconnected.</p> <ol style="list-style-type: none"> 1. Ensure Valve module is powered. 2. Ensure wire connections are secure and free of contaminates. 3. Ensure wire harness is free of damages. 4. If problem continues, contact technical support or refer to the service handbook for further instructions. 	
<p>210</p> <p>Data Error Code: (210, 35)</p>	<p>Auto Test Complete</p> <p>Cycle Main Power to water heater. If problem continues, contact technical support for further instructions.</p>	

Fault and Alert Messages		
FAULT CODE	Possible Causes - Check/Repair	Displayed Fault/Alert Message
<p>211</p> <p>Data Error Code: (211, 133)</p>	<p>No Blower Speed Feedback</p> <p>The control system has not detected the correct feedback from the blower when a command was sent to the blower to operate.</p> <ol style="list-style-type: none"> 1. Ensure both wire connections to the blower and to the control system is secure and free of contaminates 2. Ensure the wire harnesses are free from damages 3. If problem continue, contact technical support, or refer to the service handbook for further instructions. 	
<p>212</p> <p>Data Error Code: (212, xxx) where xxx - 142, 143, 144 or 146</p>	<p>Main Temperature Probe Failure</p> <p>The control system has detected an issue with the main temperature probe.</p> <p>The control system has detected an issue with the main temperature probe.</p> <ol style="list-style-type: none"> 1. Ensure the wire connections for the main temp probe are clean and secure. 2. Ensure the wire harness for the main temp probe is free from damages. 3. If the problem continues, contact technical support or refer to the service handbook for further instructions. 	
<p>213</p> <p>Data Error Code: (213, 136) or (213, 243)</p>	<p>Hardware Failure</p> <p>The control system has detected a flame sensor error.</p> <ol style="list-style-type: none"> 1. Ensure that the flame sensor wire harness is free of damages. 2. Ensure that the flame sensor wire connection on both ends is secure and free of contaminates. 3. Remove flame sensor and inspect for contaminates or damages in ceramic insulator. 4. Clean flame sensor rod with steel wool. 5. If the problem continues, contact technical support, or refer to the service handbook for further instructions. 	
<p>214</p> <p>Data Error Code: (214, xxx) where xxx =149, 153, 155 or 157</p>	<p>Software Failure</p> <p>The CSC has detected a software issue.</p> <ol style="list-style-type: none"> 1. Cycle the main power supply to the water heater by turning off the breaker/disconnect, then wait approximately 30 seconds and turn main power supply back on. 2. If problem continues, contact Technical Support or refer to the service handbook for further instructions. 	

Fault and Alert Messages		
FAULT CODE	Possible Causes - Check/Repair	Displayed Fault/Alert Message
<p>215</p> <p>Data Error Code: (215, 2400x) where x is the failed calibration reason described in the service handbook.</p>	<p>Calibration Error</p> <p>The CSC has detected a calibration error.</p> <ol style="list-style-type: none"> The CSC has detected a software issue. Cycle the main power supply to the water heater by turning off the breaker/disconnect, then wait approximately 30 seconds and turn main power supply back on. If problem continues, contact Technical Support or refer to the service handbook for further instructions. 	
<p>216</p> <p>Data Error Code: (216, 137)</p>	<p>Gas Valve Circuit Fault</p> <p>The control system has detected a fault with the Gas Valve Circuit.</p> <ol style="list-style-type: none"> Ensure wire connections on both ends are secure and free of contaminants. Ensure wire harness is not damaged. If problem continues, contact technical support, or refer to the service handbook for further instructions. 	
<p>217</p> <p>Data Error Code: (217, 242)</p>	<p>MDT Fault</p> <p>The control system has detected a fault with the Motor Driven Throttle (MDT).</p> <ol style="list-style-type: none"> Ensure wire connections on both ends are secure and free of contaminants. Ensure wire harness is not damaged. If problem continues, contact technical support, or refer to the service handbook for further instructions. 	
<p>218</p> <p>Data Error Code: (209, 2014)</p>	<p>BMS Module Disconnected</p> <p>Communication with the BMS module has been lost.</p> <p>The control system has detected that the BMS is disconnected.</p> <ol style="list-style-type: none"> Ensure BMS module is powered. Ensure wire connections are secure and free of contaminants. Ensure wire harness is free of damages. If problem continues, contact technical support or refer to the service handbook for further instructions. 	

Fault and Alert Messages		
FAULT CODE	Possible Causes - Check/Repair	Displayed Fault/Alert Message
219	<p>Anode Shorted</p> <p>The central control board (TRC) is detecting low-resistance or a short to earth ground or the tank.</p> <p>Possible Causes:</p> <ol style="list-style-type: none"> 1. Water at anode area. 2. Contamination (solder, Loctite, WD40 etc.) between the anode top and the surrounding metal. 3. Sediment build up with a possible bridge to tank. 4. A loose anode wire touching the tank. 5. A bent anode shorting to the tank or an element. 	
220	<p>Powered Anode Module Failure</p> <p>Cycle the main power to the unit off and then on.</p> <p>The commercial power anode module (CPAM) needs to be replaced.</p>	
221 Data Error Code: 13	<p>Reset Lockout</p> <p>The control system has detected a Reset Lockout</p> <ol style="list-style-type: none"> 1. Cycle the main power to the water heater. 2. If problem continues, contact technical support, or refer to the service handbook for further instructions. 	
222 Data Error Code: (222, 2001)	<p>FMM Missing</p> <p>The control system has detected that the Flex Memory Module (FMM) is either missing or disconnected.</p> <ol style="list-style-type: none"> 1. Ensure the wire connections are secure and free of contaminates. 2. Ensure wire connection at terminal J2 on the TRC is secure. 3. Ensure all wire harnesses are free from damages. 4. Cycle the main power to the water heater. 5. If problem continues, contact technical support for further instructions. 	

Fault and Alert Messages		
FAULT CODE	Possible Causes - Check/Repair	Displayed Fault/Alert Message
<p>223</p> <p>Data Error Code: (223, 2006)</p>	<p>Missing Display</p> <p>The display was found to be missing.</p> <p>The control system has detected that the User Interface Module (UIM) is either missing or disconnected.</p> <ol style="list-style-type: none"> 1. Ensure the wire connections are secure and free of contaminates. 2. Ensure wire connection at terminal J2 on the TRC is secure. 3. Ensure all wire harnesses are free from damages. 4. Cycle the main power to the water heater. 5. If problem continues, contact technical support for further instructions. 	
<p>224</p> <p>Data Error Code: (224, 2005)</p>	<p>TRC Software or Hardware Is Old</p> <p>The control system has detected that the Software or Hardware Version on the TRC is outdated.</p> <p>The control system has detected that the Software or Hardware Version on the TRC is outdated.</p> <ol style="list-style-type: none"> 1. Typically caused by replacing control system components with an older revision software. 2. Contact technical support for further instructions. 	
<p>225</p> <p>(225, 2007)</p>	<p>Display software or hardware is old.</p> <p>The control system has detected that the Software Hardware Version on the UIM is outdated.</p> <ol style="list-style-type: none"> 1. Typically caused by replacing control system components with an older revision software. 2. Contact technical support for further instructions. 	
<p>226</p> <p>(226, 60xy)</p> <p>where x = 0 is on TRC-1000 board anode circuit. x = 1 is CPAM 1, x = 2 is CPAM 2 etc. y = 1, 2, 3, 5, 6 or 8)</p>	<p>Powered Anode Circuit Failure</p> <p>The control system has detected a failure with the Powered Anode Circuit.</p> <ol style="list-style-type: none"> 1. Cycle main power to the water heater. 2. Contact technical support for further instructions. 	

Fault and Alert Messages		
FAULT CODE	Possible Causes - Check/Repair	Displayed Fault/Alert Message
227 (227, 4001)	<p>FMM Incompatible</p> <p>The control system has detected that the Software Version on the Flex Memory Module (FMM) is outdated.</p> <p>The control system has detected that the Software Version on the Flex Memory Module (FMM) is outdated</p> <ol style="list-style-type: none"> Typically caused by replacing control system components with an older revision software Contact technical support for further instructions 	
228 (228, 2015)	<p>User Setpoints Error Detected</p> <p>Data corruption of user adjustable setpoints led to factory reset of default values.</p> <p>Toggle the Enable/Disable switch to Diable, wait 30 seconds and toggle back to Enable to clear fault and readjust setpoints.</p>	

CHECKING FOR LEAKS

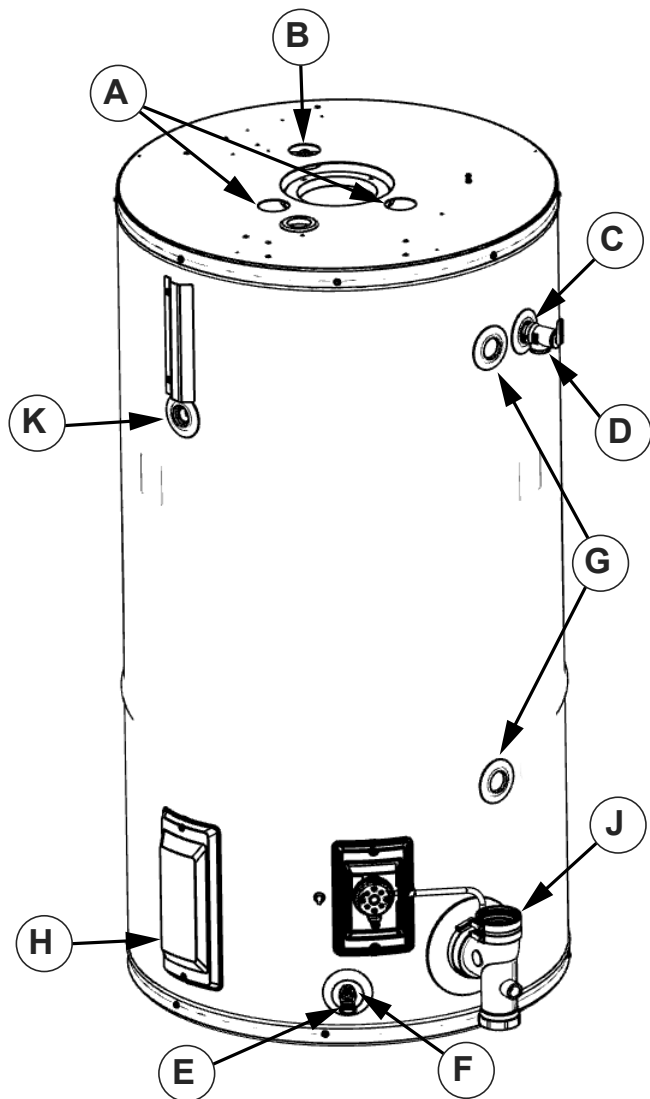

Figure 43. Leakage Checkpoints

Never use this water heater unless it is completely filled with water. To prevent damage to the tank, the tank must be filled with water. Water must flow from the hot water faucet before turning "ON" gas to the water heater.

- A. *Condensation may be seen on pipes in humid weather or pipe connections may be leaking.
- B. *The anode rod fitting may be leaking.
- C. Small amounts of water from temperature-pressure relief valve may be due to thermal expansion or high water pressure in your area.
- D. *The temperature-pressure relief valve may be leaking at the tank fitting.
- E. Water from a drain valve may be due to the valve being slightly opened.
- F. *The drain valve may be leaking at the tank fitting.
- G. Leakage from recirculation plug or pipe connection.
- H. Leakage from the plug under the clean-out cover.
- I. Leakage from the temperature probe connection (Not shown in figure).
- J. Condensate from the exhaust connection.
- K. *The temperature probe fitting may be leaking.

Leakage from other water heaters, water lines, or ground seepage should also be checked.

* To check where threaded portion enters tank, insert cotton swab between jacket opening and fitting. If cotton is wet, follow "Draining" instructions in the "Periodic Maintenance" section and then remove fitting. Put pipe dope or thread-sealer tape on the threads and replace. Then follow "Filling the Water Heater" instructions in the "Installing the New Water Heater" section.

WATER LEAK DETECTION

The water heaters covered by this manual have a water leak detection feature that senses the buildup of water in vicinity of the appliance, setting off an alarm to alert the end user. Please see the installation instructions in included kit.

WARNING	
Safety Hazard	
	<p>Failure to follow these instructions and safety messages could result in death or serious injury.</p> <p>Read and understand this instruction manual and the safety messages herein before installing, operating or servicing this water heater.</p> <p>This manual must remain with the water heater.</p>

DIAGRAMS

CAUTION

Electrical Shock Hazard



Wiring errors can cause improper and dangerous operation, resulting in property damage, injury or death.

- Label all wires prior to disconnection when servicing controls.
- Verify proper operation after servicing.

WARNING

Electrical Shock Hazard



- Disconnect from electrical supply before servicing unit. Replace all doors and panels before operating heater.
- If any of the original wires supplied with the appliance must be replaced, they must be replaced with appliance wire material with minimum temperature rating of 221°F (105°C) and a minimum size of No. 18 AWG.

WIRING DIAGRAM

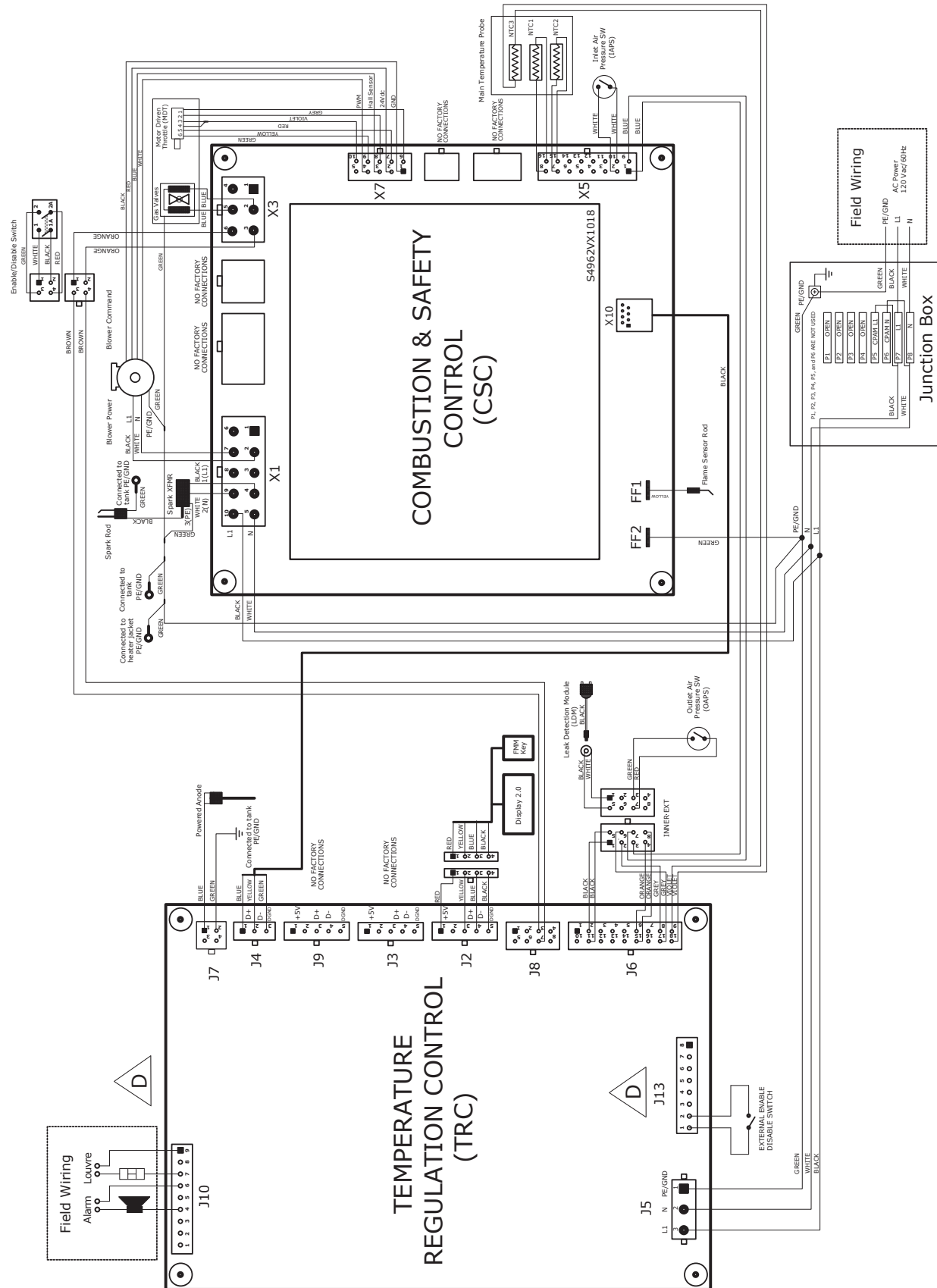

Figure 44. Wiring Diagram

